

TOSHIBA

SERVICE MANUAL

REVERSING AUTOMATIC DOCUMENT FEEDER

MR-3018



© 2005 TOSHIBA TEC CORPORATION

All rights reserved

General Precautions for Installation/Service/Maintenance for the MR-3018

The installation and service should be done by a qualified service technician.

- 1) When installing the MR-3018 to the Equipment, be sure to follow the instructions described in the "Unpacking/Set-Up Procedure for the MR-3018" booklet which comes with each unit of the MR-3018.
- 2) The MR-3018 should be installed by an authorized/qualified person.
- 3) Before starting installation, servicing or maintenance work, be sure to turn OFF and unplug the equipment first.
- 4) When servicing or maintaining the MR-3018, be careful about the rotating or operation sections such as gears, pulleys, sprockets, cams, belts, etc.
- 5) When parts are disassembled, reassembly is basically the reverse of disassembly unless otherwise noted in this manual or other related materials. Be careful not to reassemble small parts such as screws, washers, pins, E-rings, toothed washers to the wrong places.
- 6) Basically, the machine should not be operated with any parts removed or disassembled.
- 7) Delicate parts for preventing safety hazard problems (such as switches, sensors, etc. if any) should be handled/installed/adjusted correctly.
- 8) Use suitable measuring instruments and tools.
- 9) During servicing or maintenance work, be sure to check the serial No. plate and other cautionary labels (if any) to see if they are clean and firmly fixed. If not, take appropriate actions.
- 10) The PC board must be stored in an anti-electrostatic bag and handled carefully using a wristband, because the ICs on it may be damaged due to static electricity. Before using the wrist band, pull out the power cord plug of the equipment and make sure that there is no uninsulated charged objects in the vicinity.
- 11) For the recovery and disposal of used MR-3018, consumable parts and packing materials, follow the relevant local regulations/rules should be followed.
- 12) After completing installation, servicing and maintenance of the MR-3018, return the MR-3018 to its original state, and check operation.

CONTENTS

1. Specification	1-1
2. GENERAL DESCRIPTION.....	2-1
2.1 Main Components.....	2-1
2.2 Sectional View	2-2
2.3 Electric Parts Layout.....	2-3
2.4 Symbols and Functions of Various Components.....	2-4
2.5 Diagram of Signal Blocks.....	2-5
2.6 Description of Interface Signals	2-6
3. DESCRIPTION OF OPERATIONS	3-1
3.1 DRIVE SYSTEM.....	3-1
3.1.1 Outline	3-1
3.1.2 Original feed motor drive section.....	3-2
3.1.3 Read motor drive section	3-3
3.1.4 Original exit/reverse motor drive section	3-4
3.2 Original Size Detection	3-5
3.2.1 Outline	3-5
3.2.2 Original tray width sensor.....	3-5
3.2.3 Original width detection sensors-1 and -2 / Original length detection sensor.....	3-6
3.3 FLOW CHART	3-8
3.4 DESCRIPTION OF CIRCUIT.....	3-16
3.4.1 Drive Circuit for Feed Motor	3-16
3.4.2 Drive Circuit for Read Motor.....	3-17
3.4.3 Drive Circuit for Exit Motor	3-18
3.4.4 Drive Circuit for FAN Motor	3-18
3.4.5 Reset Circuit	3-19
3.4.6 Drive Circuit for Pickup Solenoid	3-19
3.4.7 Drive Circuit for Gate Solenoid	3-20
4. DISASSEMBLY AND ASSEMBLY	4-1
4.1 Cover	4-1
4.2 Roller	4-6
4.3 Motor / Motor drive section	4-18
4.4 Solenoid.....	4-24
4.5 Sensor/switch	4-26
4.6 PC Board	4-34
4.7 Others	4-35
5. Adjustment.....	5-1
5.1 Adjustment of Position	5-1
5.2 Adjustment of Height	5-6
5.3 Adjustment of Skew.....	5-8
5.4 Adjustment of the Leading Edge Position.....	5-11
5.5 Adjustment of Horizontal Position.....	5-13
5.6 Adjustment of Copy Ratio	5-14
5.7 Adjustment of RADF Opening/Closing Sensor.....	5-15
6. Troubleshooting	6-1
6.1 Troubleshooting for Mechanical Errors.....	6-1
6.2 Troubleshooting for Electrical Errors	6-2
7. MAINTENANCE AND REWRITING ROM	7-1
7.1 Periodic Maintenance	7-1
7.2 Rewriting ROM (Firmware Updating).....	7-2

8. CIRCUIT DIAGRAM / HARNESS DIAGRAM 8-1
8.1 Assembly of PC Board..... 8-1
8.2 Circuit Diagram 8-2
8.3 Control PC Board Circuit 8-4

1. Specification

Item	Contents	Remarks
Maximum number of originals on the original feeding tray	Up to 100 sheets or 16 mm in height.	35 - 80 g/m ² (9.3 - 21.3 lb. Bond)
Acceptable paper size	A5-R, A4, A4-R, B5, B5-R, B4, A3, FOLIO, ST-R, LT, LT-R, LG, LD, COMPUTER	
Acceptable paper weight	1-sided: 35 - 157 g/m ² (9.3 lb. Bond - 58 lb. Cover) 2-sided: 50 - 157 g/m ² (13.3 lb. Bond - 58 lb. Cover)	
Dimensions	W600 x D523 x H135 (mm)	Excluding hinges and original tray
Weight	12.5 kg	
Power consumption	Approx. 49.5 W	
Power requirements	DC5 V, DC24 V	Supplied from the equipment
Co-packed items	Unpacking Instruction (1 set) Charts (A4/LT: 1 sheet each) Mounting screws (6 pcs) Positioning pins (2 pcs) Washer (1 pc)	

2. GENERAL DESCRIPTION

2.1 Main Components

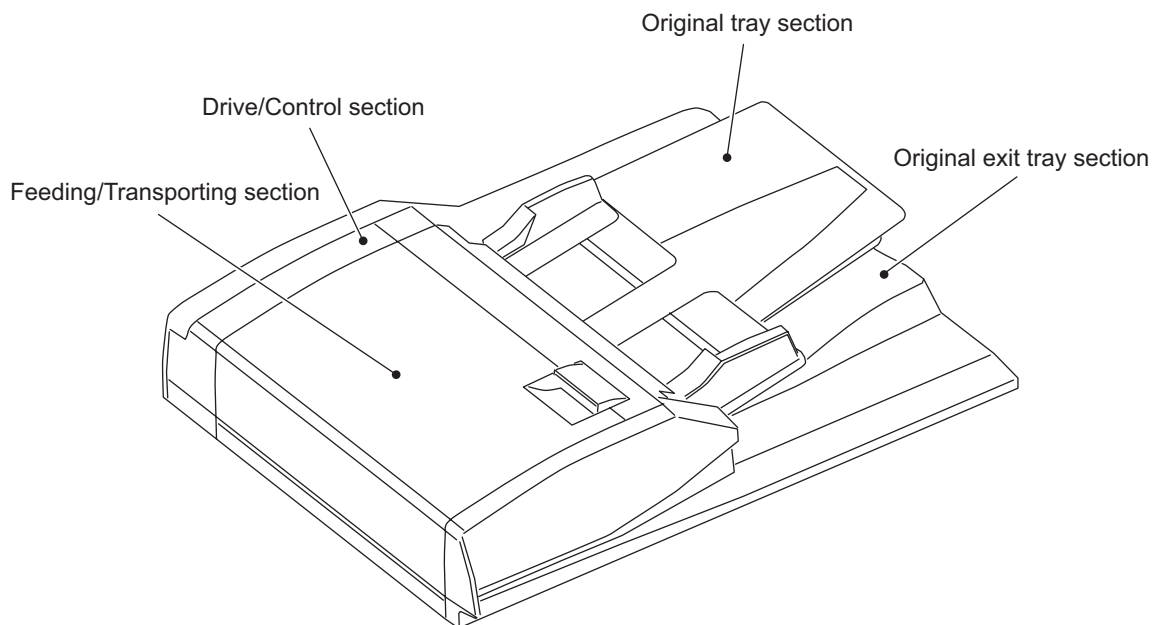

Fig.2-1

Location	Components	
Feeding/Transporting section	Pickup roller Feed roller Separation roller Registration roller Intermediate transfer roller Pre-reading roller Platen roller Post-reading roller Exit/reverse roller Reverse registration roller	Original empty sensor (S3) Original length detection sensor (S4) Original registration sensor (S5) Original width detection sensor-1 (S6) Original width detection sensor-2 (S7) Original intermediate transport sensor(S8) Read sensor (S9) Original exit/reverse sensor (S10) Jam access cover sensor (S11)
Original tray section	Original width guide Original tray Original reverse tray	Original tray sensor (S1) Original tray width sensor (S2)
Original exit tray section	Original exit tray	
Drive/Control section		Original feed motor (M1) Read motor (M2) Original exit/reverse motor (M3) Fan motor (M4) Original pickup solenoid (SOL1) Gate solenoid (SOL2) RADF opening/closing sensor (S12) Jam access cover opening/closing switch (SW1) RADF control PC board (ADF)

2.2 Sectional View

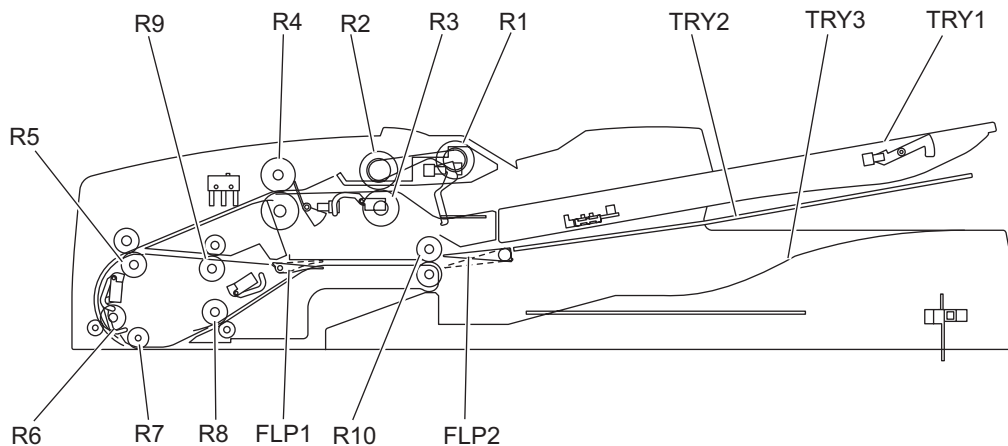

Fig.2-2

TRY1	Original tray	R4	Registration roller
TRY2	Original reverse tray	R5	Intermediate transfer roller
TRY3	Original exit tray	R6	Pre-reading roller
FLP1	Exit gate	R7	Platen roller
FLP2	Reverse flapper	R8	Post-reading roller
R1	Pickup roller	R9	Reverse registration roller
R2	Feed roller	R10	Exit/reverse roller
R3	Separation roller		

2.3 Electric Parts Layout

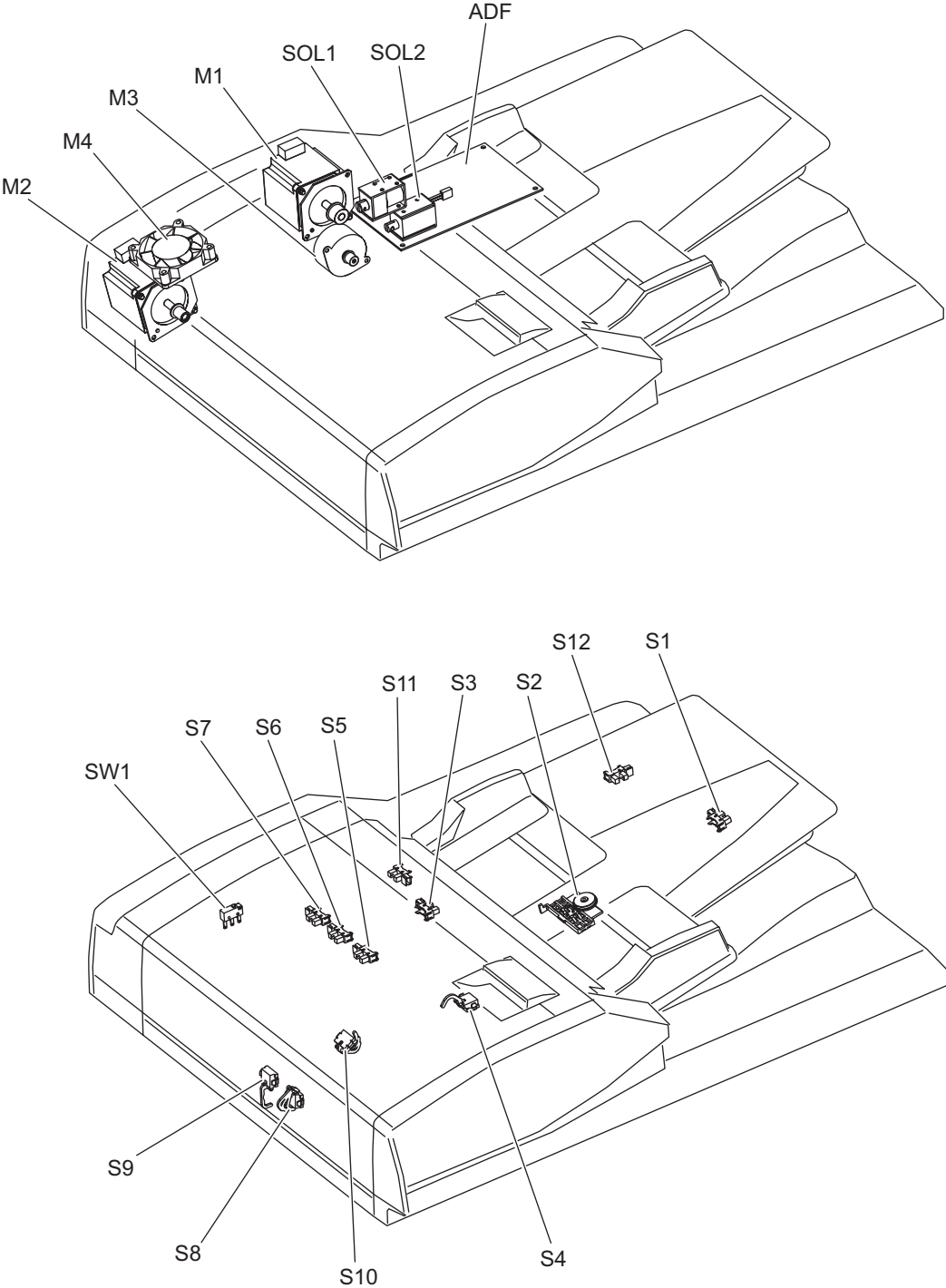

Fig.2-3

2.4 Symbols and Functions of Various Components

1) Motors

Symbol	Name	Function
M1	Original feed motor	Drives the original feed roller, pickup roller and registration roller.
M2	Read motor	Transports originals by driving the intermediate transport roller, front read roller, platen roller, rear read roller and reverse registration roller.
M3	Original exit/reverse motor	Drives the original exit/reverse roller.
M4	Fan motor	Cools off the ADF drive section and ADF board.

2) Sensors and Switches

Symbol	Name	Function
S1	Original tray sensor	Detects the length of the original set on the original tray.
S2	Original tray width sensor	Detects the width of the original set on the original tray.
S3	Original empty sensor	Detects the original set on the original tray.
S4	Original length detection sensor	Detects the length of the original.
S5	Original registration sensor	Detects transport of the original at the registration roller section.
S6	Original width detection sensor-1	Detects the width of the original.
S7	Original width detection sensor-2	Detects the width of the original.
S8	Original intermediate transport sensor	Detects the original transported to the Pre-scanning section.
S9	Read sensor	Detects the leading edge of the original at the original scanning section.
S10	Original exit/reverse sensor	Detects the exit (transit) of an original. Also detects the stop reference position for an original when in reverse.
S11	Jam access cover sensor	Detects opening/closing of the Jam access cover.
S12	RADF opening/closing sensor	Detects opening/closing of the RADF.
SW1	Jam access cover opening/closing switch	Switches between cutoff and supply state of the 24 V power by opening/closing of the jam access cover.

3) Solenoid

Symbol	Name	Function
SOL1	Original pickup solenoid	Drives up and down the original pickup roller.
SOL2	Gate solenoid	Drives the reverse flapper. (Switches the flapper to the reverse side when turned to ON.)

4) PC board

Symbol	Name	Function
ADF	RADF control PC board (ADF board)	Controls the RADF.

2.5 Diagram of Signal Blocks

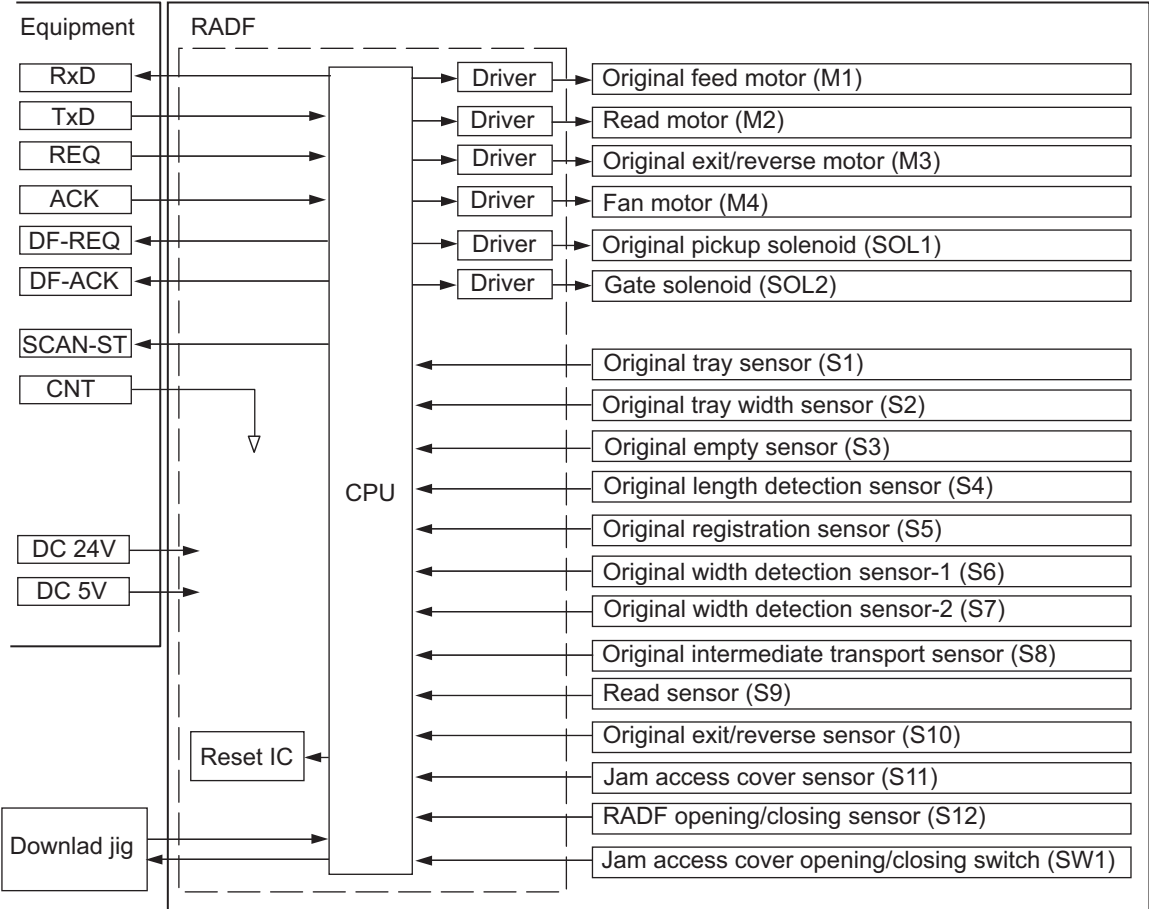

Fig.2-4

2.6 Description of Interface Signals

The following 6 lines are used to transmit/receive signals between the equipment and the RADF.

- REQCommunication request signal (from equipment to the RADF)
- DF-REQCommunication request signal (from the RADF to equipment)
- DF-ACK.....Communication request acknowledging signal (from the RADF to equipment)
- ACK.....Communication request acknowledging signal (from equipment to the RADF)
- TxDData transmitted from equipment to the RADF
- RxDData transmitted from the RADF to equipment

Data communication (RxD and TxD) between the scanner and the RADF has adopted the serial communication system which does not allow checking using testing devices to see whether the signals are transmitted/received properly in the field.

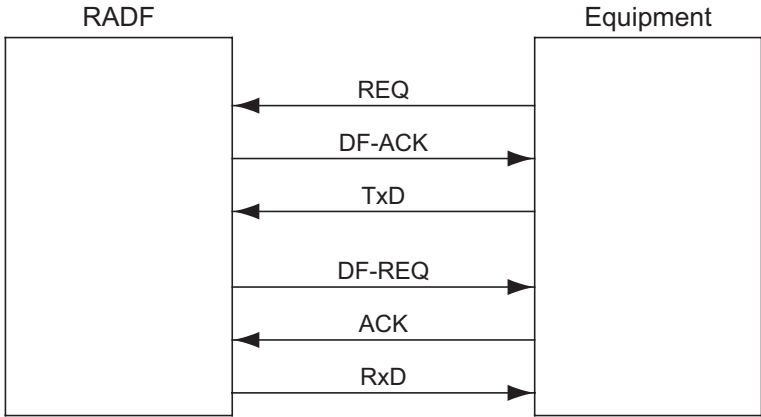

Fig.2-5

3. DESCRIPTION OF OPERATIONS

3.1 DRIVE SYSTEM

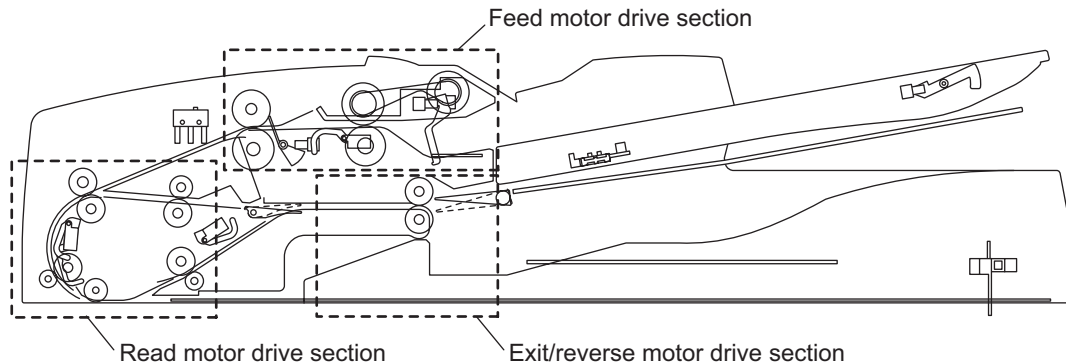

Fig.3-1

3.1.1 Outline

Originals are transported by the original feed motor, read motor and original exit/reverse motor. Each motor has a drive section for the following operations:

- Original feed motor drive section: picks up originals and drives the registration roller.
- Read motor drive section: transports originals and drives parts such as the platen roller.
- Original exit/reverse motor drive section: exits and reverses originals, and drives the exit/reverse roller.

The Original feed motor rotates reversely when the originals are being transported at the registration roller, compared to its rotational direction when they are being picked up.

The original exit/reverse motor also rotates reversely when the originals are being reversed and transported, compared to its rotational direction when they are being exited.

The read motor always rotates in a constant direction.

3.1.2 Original feed motor drive section

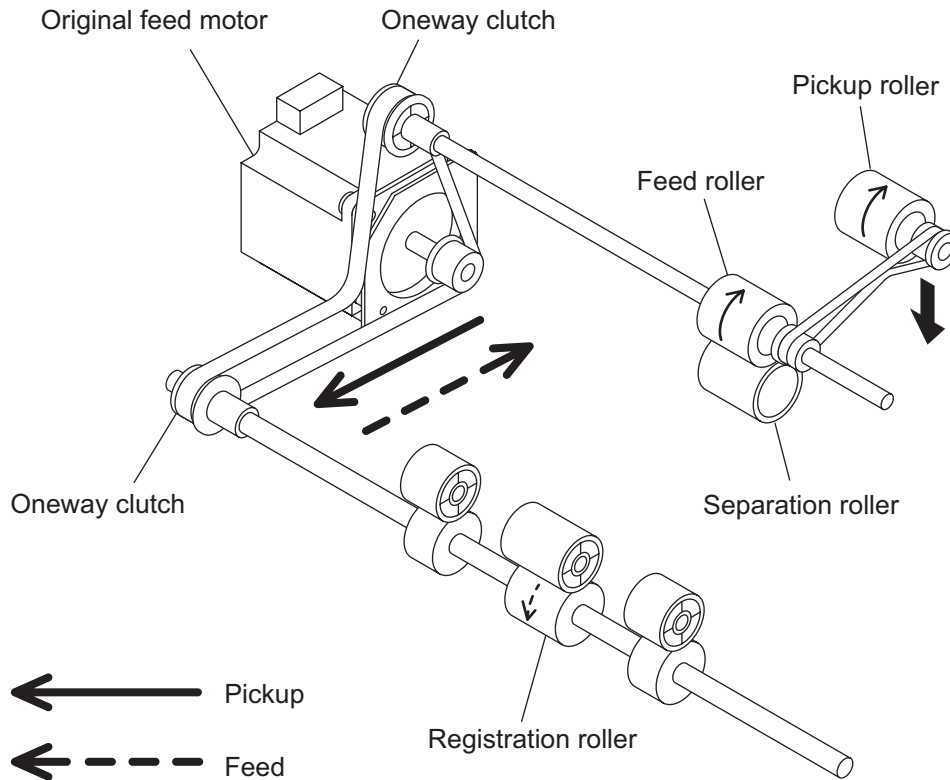

Fig.3-2

When an original is placed on the original tray and the RADF receives a feed request signal from the equipment, the feeding of the original is started. The original empty sensor detects the presence of the original, and then the pickup roller is lowered by the drive from the original pickup solenoid. The Original feed motor rotates, and the pickup roller and the feed roller then rotate in a normal direction (shown in a solid line in the figure) to guide the original into the transport path. Then the original is transported to the registration roller to be aligned. The original aligned with the registration roller is then transported by the reverse rotation of the Original feed motor (shown in a dotted line in the figure). A one-way clutch is installed inside of each gear of the feed roller and the registration roller, so these gears will not be driven in a reverse rotation. When the original empty sensor detects that there is no original on the original tray, the original pickup solenoid is turned OFF and the pickup roller is raised. The original pickup solenoid is the one can operate both suction and recovery.

3.1.3 Read motor drive section

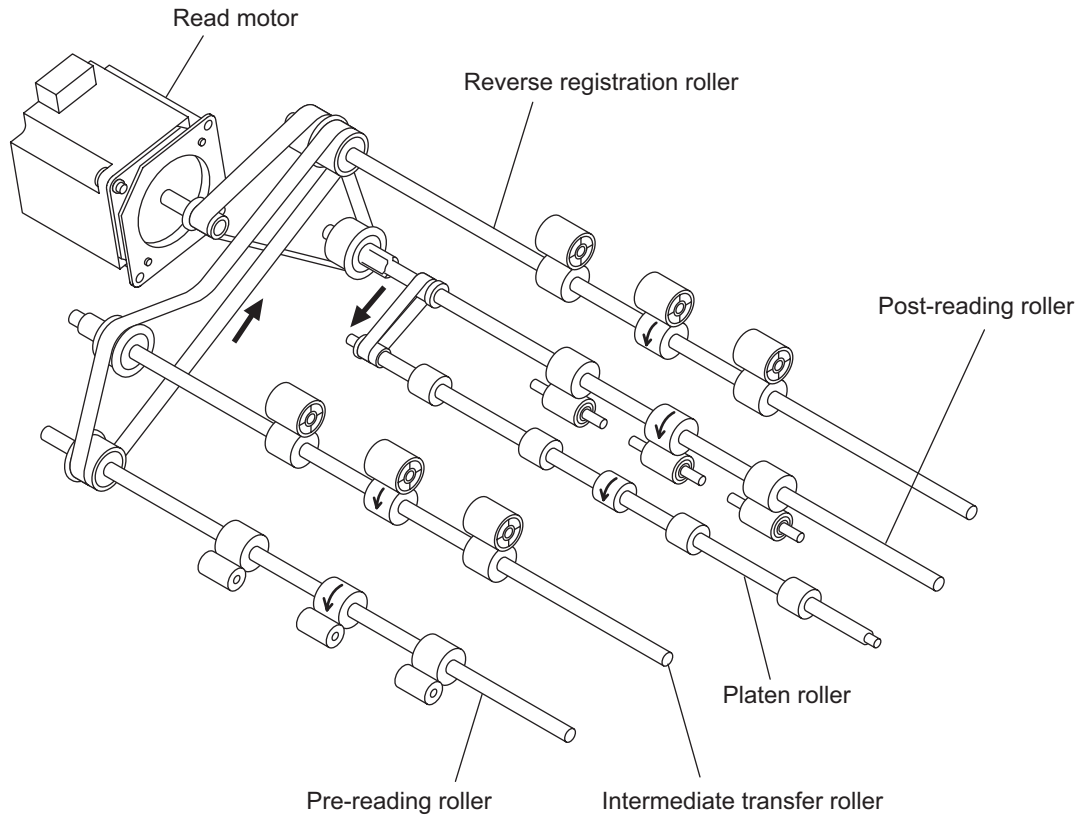

Fig.3-3

The transported original is driven by the read motor.
Then the original is transported to a scanning start position by the intermediate transfer roller, pre-reading roller and platen roller.
The original transported to the scanning start position is then scanned in the scanner function of the equipment.
When the data of the original have been scanned, the original is then transported to the original exit tray side by the post-reading roller.

3.1.4 Original exit/reverse motor drive section

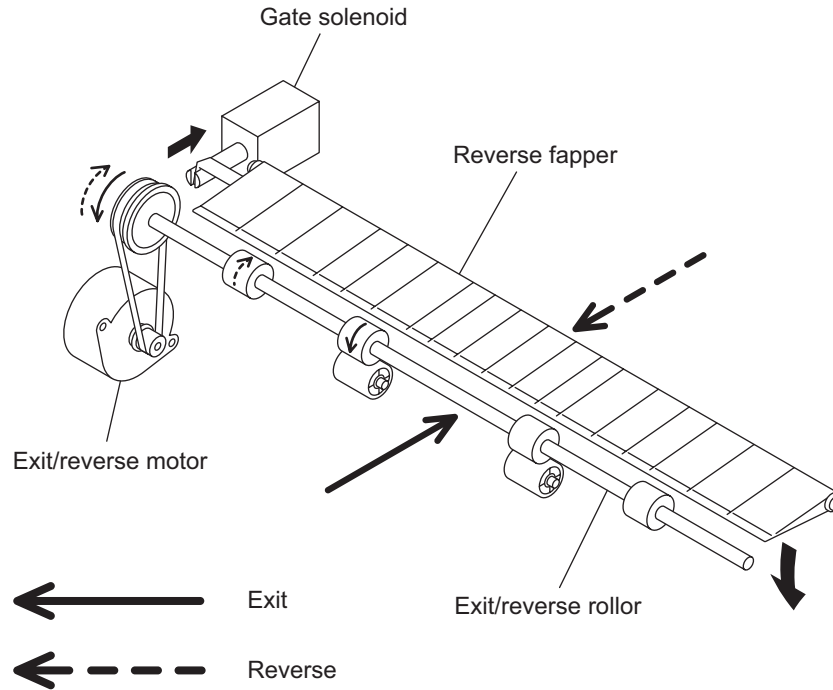

Fig.3-4

When the data of the original have been scanned, the original is exited to the original exit tray by the exit/reverse roller driven by the exit motor (shown in a solid line in the figure).

In the duplex scanning mode, the gate solenoid is turned ON and the reverse flapper is lowered to switch the transport path to the reverse tray side when the scanning of one side of the original is completed.

When the reverse flapper is lowered, the original is temporarily transported to the reverse tray, and then the exit motor rotates reversely to return the original to the transport path switched for reverse operation (shown in a dotted line in the figure).

The reversed original is aligned with the reverse registration roller, and then the other side of the original is scanned. When the scanning is completed, the original is exited to the original exit tray.

3.2 Original Size Detection

The original tray width sensor, original length detection sensor, and original width detection sensors-1 and -2 work in combination to detect the size of originals.

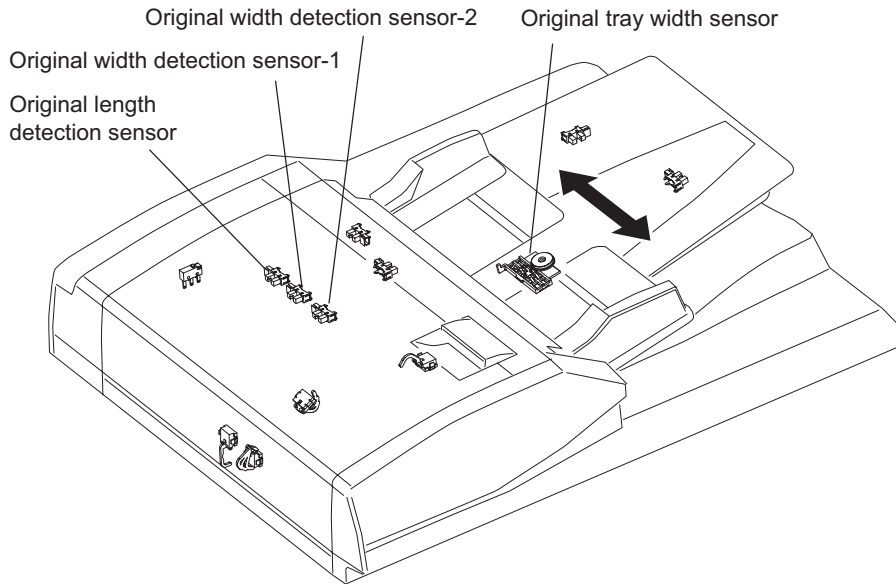

Fig.3-5

3.2.1 Outline

When an original is placed on the original tray, the width of the original is detected by the positions of the original width guides. Then the original width sensors -1 and -2 and the original length detection sensor detect the size of the original being transported. Based on the detection result of these sensors, the size of the original is finally determined.

3.2.2 Original tray width sensor

The original tray width sensor detects the width of the original placed on the original tray. This sensor consists of a leaf spring and 4 contacting points (= 4 harnesses). When the original width guides are moved, a protruded part located under the guides pushes the leaf spring, and the leaf spring thus contacts the harnesses. The gap between these guides is detected by this contact. A terminal connected with the black harness is for grounding (= common). When the leaf spring contacts with each harness of gray, yellow and orange, each terminal connected with these harnesses generates a signal at a low level. The combination of these contact (= low level) and release (= high level) can determine the width of the original.

Sizes detectable in combination of these contact and release are as follows:

TWIDTH2 (Orange)	TWIDTH1 (Yellow)	TWIDTH0 (Gray)	Original width size
H	H	H	LD / LT
H	H	L	-
H	L	H	ST-R
L	H	H	LD / LT
L	H	L	-
L	L	H	8.5x8.5 / LT-R / KLG / 13"LG
L	L	L	COMPUTER

H (= high level): Release L (= low level): Contact

3.2.3 Original width detection sensors-1 and -2 / Original length detection sensor

The size of the original is determined by the detection performed in combination of the original width detection sensors-1 and -2 and the original length detection sensor, as well as the detection performed by the original tray width sensor.

Sizes detectable in combination of these sensors are as follows:

A4 series (ORG-SRS: 1)

Original length detection sensor	Original width sensor-1	Original width sensor-2	Size determined	Original tray width
OFF	OFF	OFF	A5-R	-
	ON	OFF	B5	-
	ON	ON	A4	-
ON	OFF	OFF	B5-R	-
	ON	OFF	A4-R / FOLIO	Determined by a gap between guides
	ON	ON	A3	

A4 series (width sizes mixed at A3 / A4 standard)

Original length detection sensor	Original width sensor-1	Original width sensor-2	Size determined	Original tray width
ON	ON	ON	A3	A3 / A4
	OFF	OFF	A4-R / FOLIO	
	ON	OFF	B4	
OFF	ON	OFF	B5	
	ON	ON	A4	

A4 series (width sizes mixed at B4 / B5 standard)

Original length detection sensor	Original width sensor-1	Original width sensor-2	Size determined	Original tray width
ON	OFF	OFF	A4-R / FOLIO	B4/B5
	ON	OFF	B4	
OFF	ON	OFF	B5	
	OFF	OFF	A5-R	

A4 series (width sizes mixed at A4-R standard)

Original length detection sensor	Original width sensor-1	Original width sensor-2	Size determined	Original tray width
ON	OFF	OFF	B5-R	A4-R
	ON	OFF	A4-R / FOLIO	
OFF	OFF	OFF	A5-R	

A4 series (width sizes mixed at B5-R standard)

Original length detection sensor	Original width sensor-1	Original width sensor-2	Size determined	Original tray width
ON	OFF	OFF	B5-R	B5-R
OFF	OFF	OFF	A5-R	

LT series (ORG-SRS: 0)

Original length detection sensor	Original width sensor-1	Original width sensor-2	Size determined	Original tray width
OFF	OFF	OFF	ST-R	-
	ON	OFF	8.5x8.5	-
	ON	ON	A4	-
ON	ON	OFF	LT-R / LG / COMP / 13"LG	-
	ON	ON	LD	-

LT series (width sizes mixed at LD / LT standard)

Original length detection sensor	Original width sensor-1	Original width sensor-2	Size determined	Original tray width
ON	ON	ON	LD	LD / LT
	ON	OFF	COMP	
	OFF	OFF	LT-R / LG / 8.5x8.5 / 13"LG	
OFF	ON	ON	LT	

LT series (width sizes mixed at LG / LT-R standard)

Original length detection sensor	Original width sensor-1	Original width sensor-2	Size determined	Original tray width
ON	ON	OFF	LT-R / LG / 8.5x8.5 / 13"LG	LD / LT
OFF	OFF	OFF	ST-R	

3.3 FLOW CHART

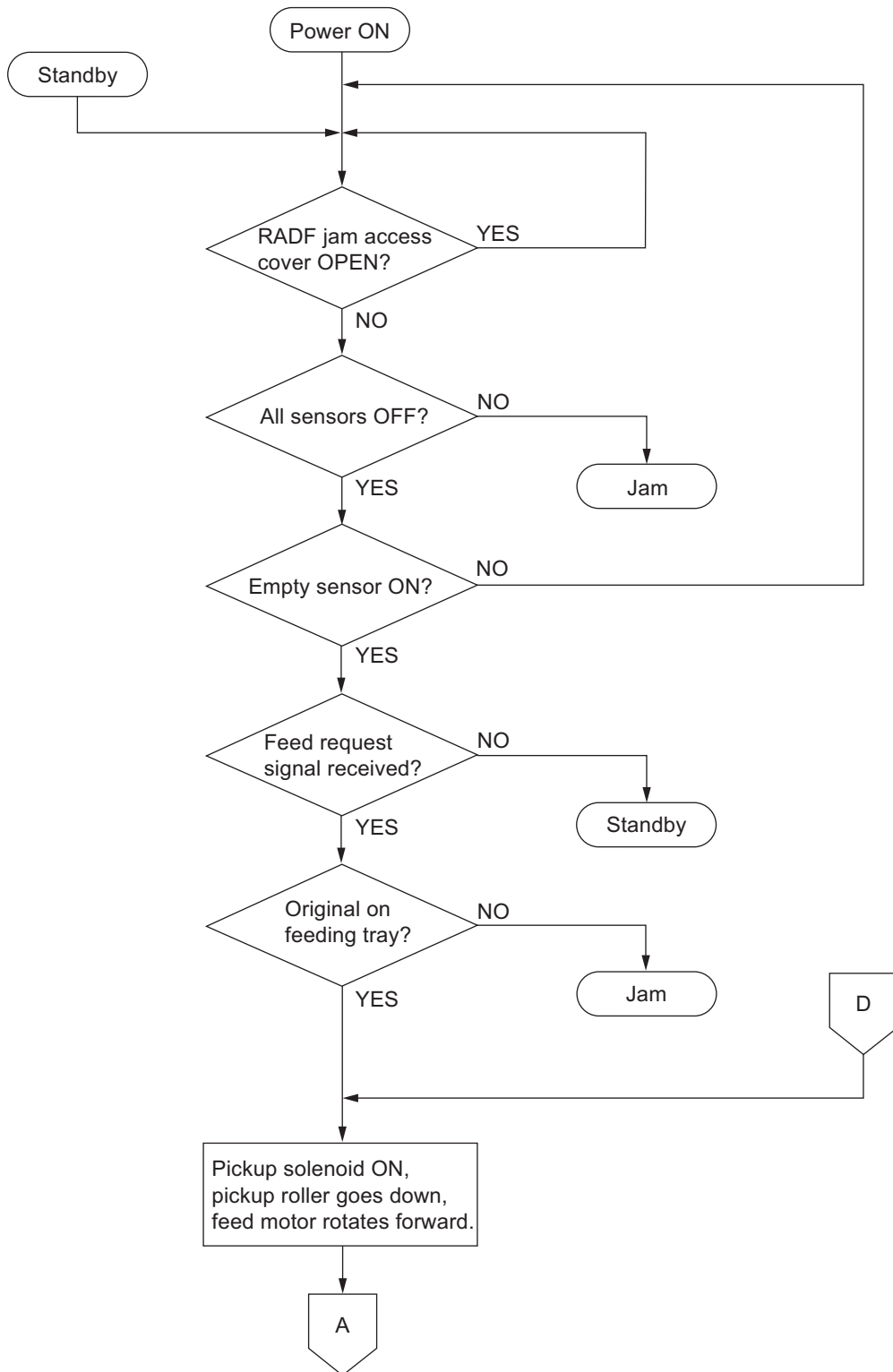

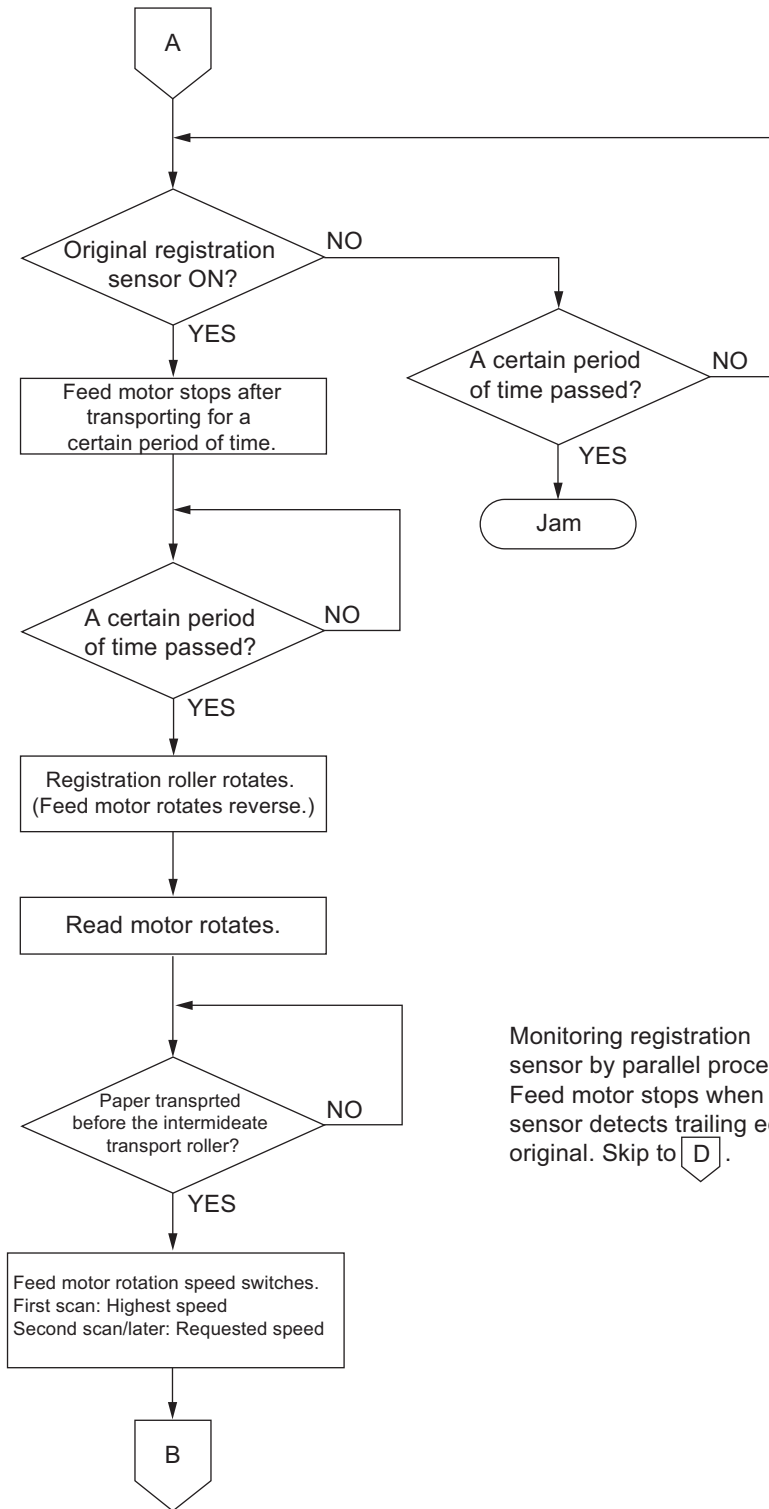

Monitoring registration sensor by parallel processing. Feed motor stops when registration sensor detects trailing edge of original. Skip to **D**.

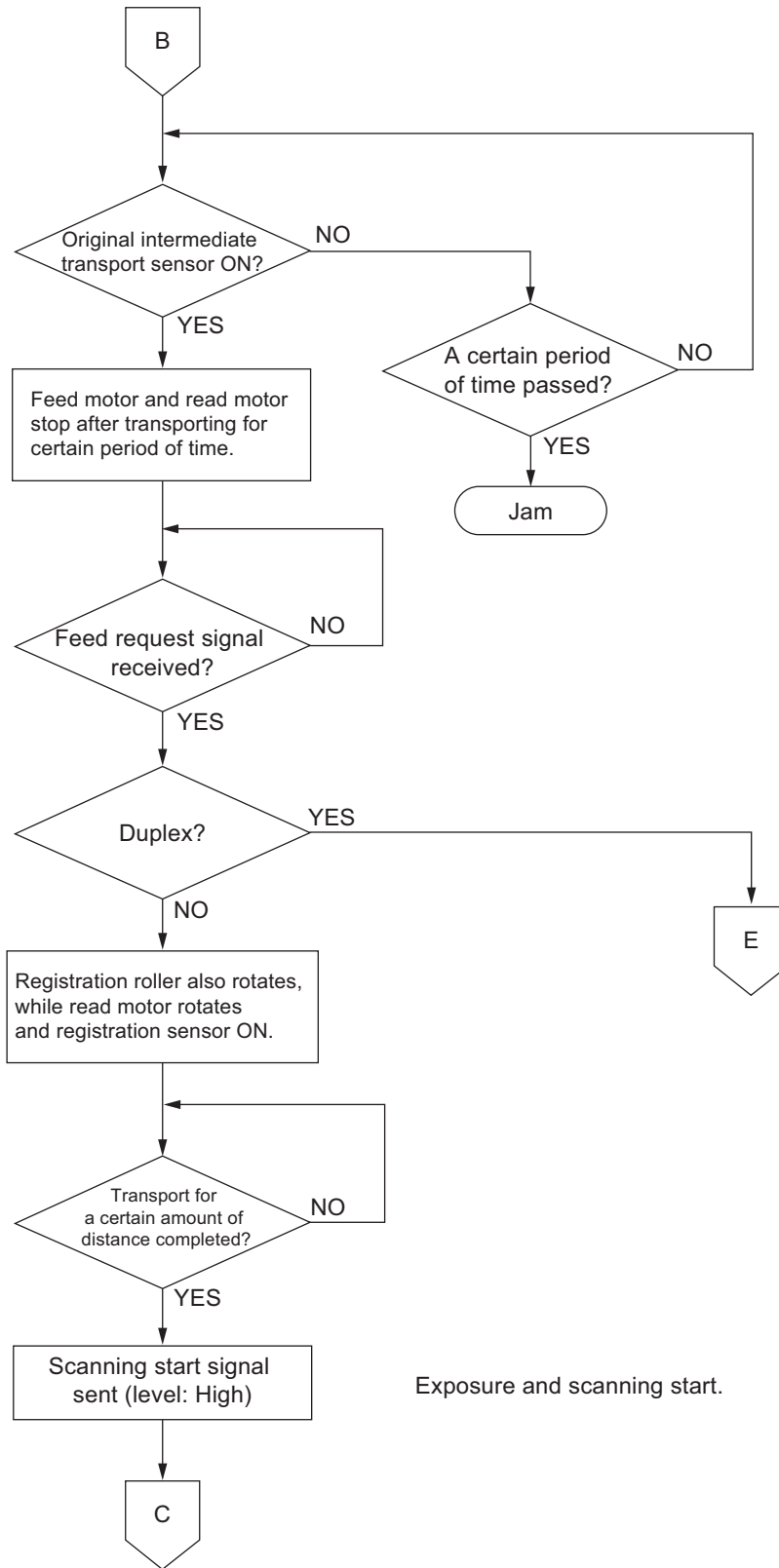

Exposure and scanning start.

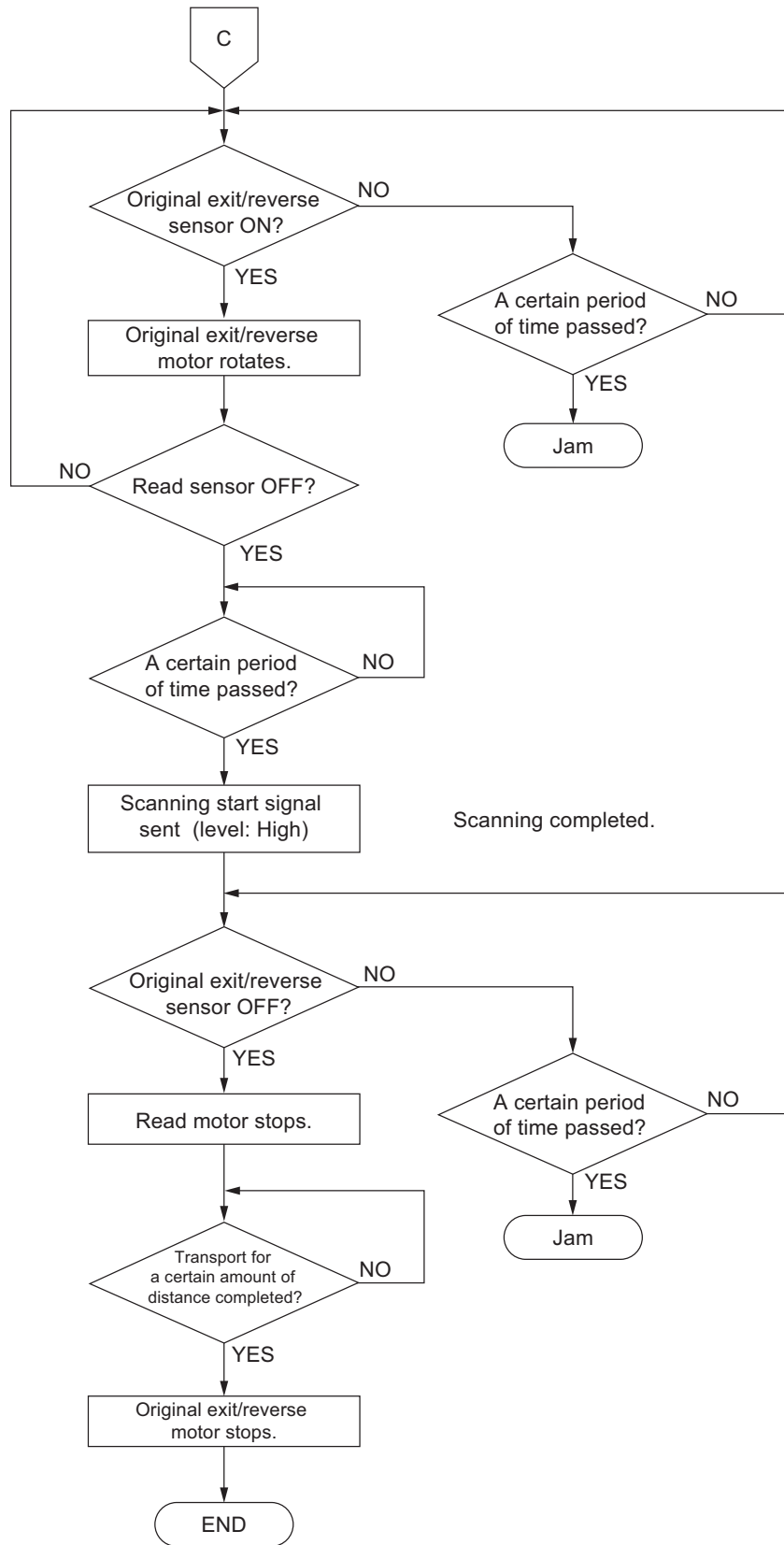

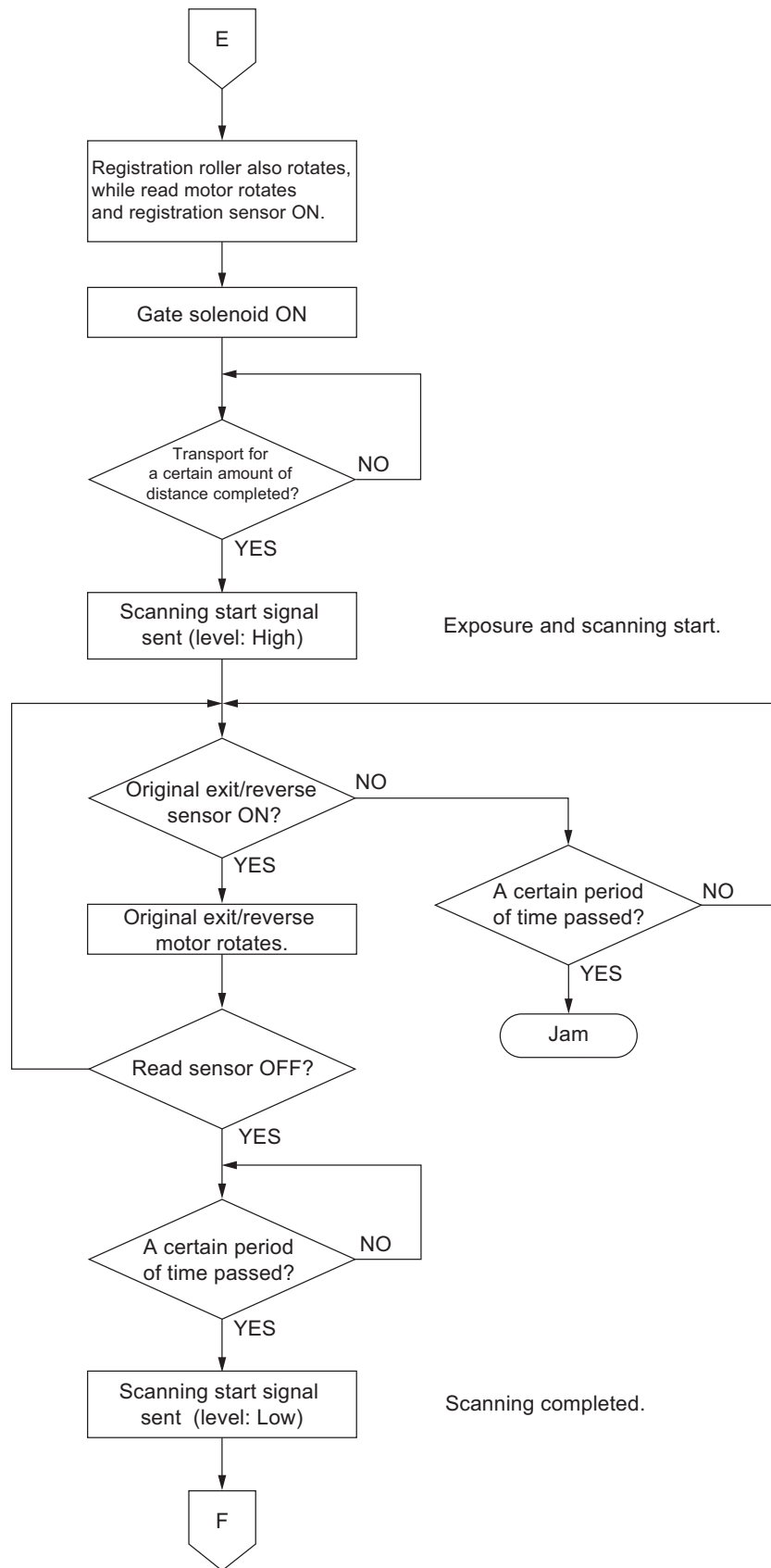

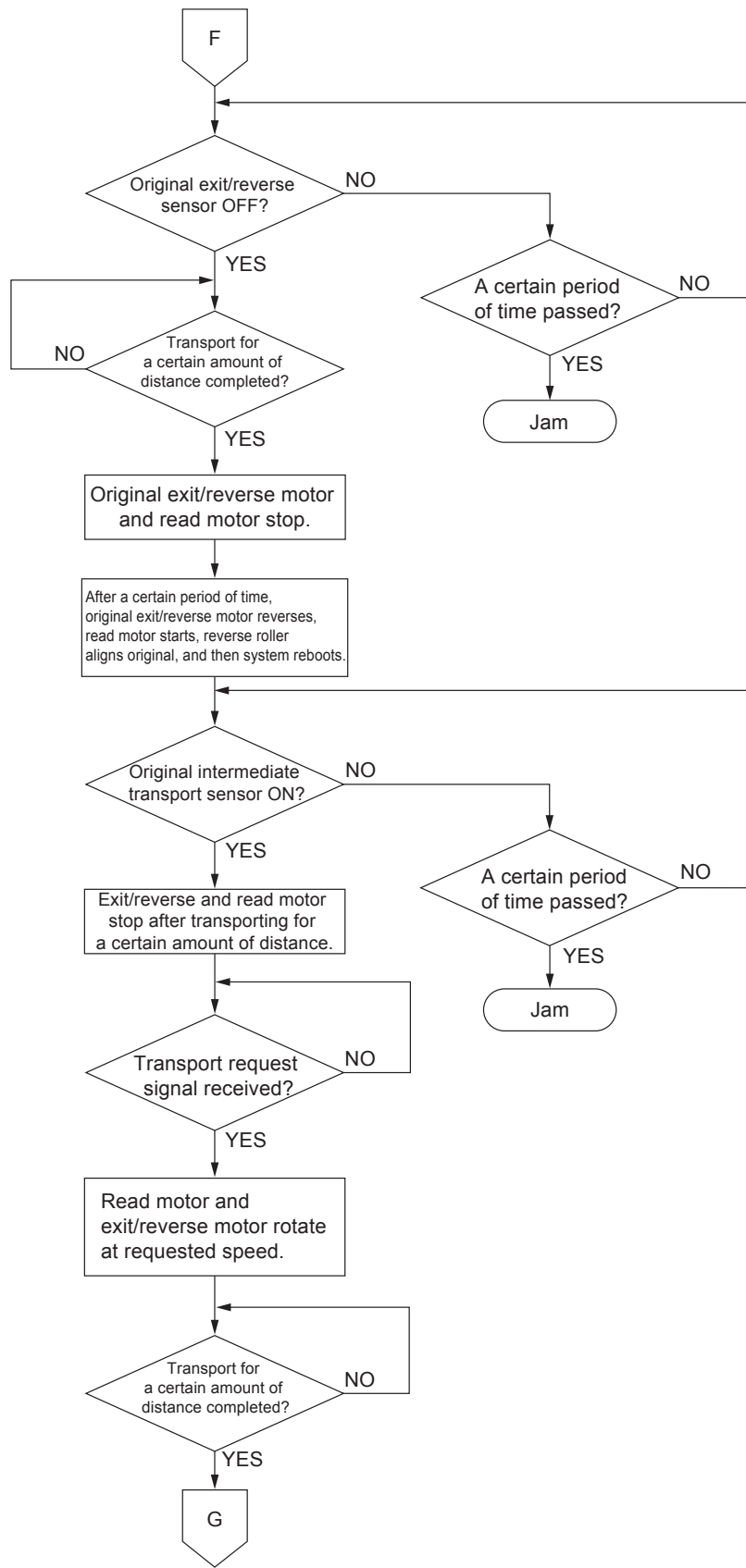

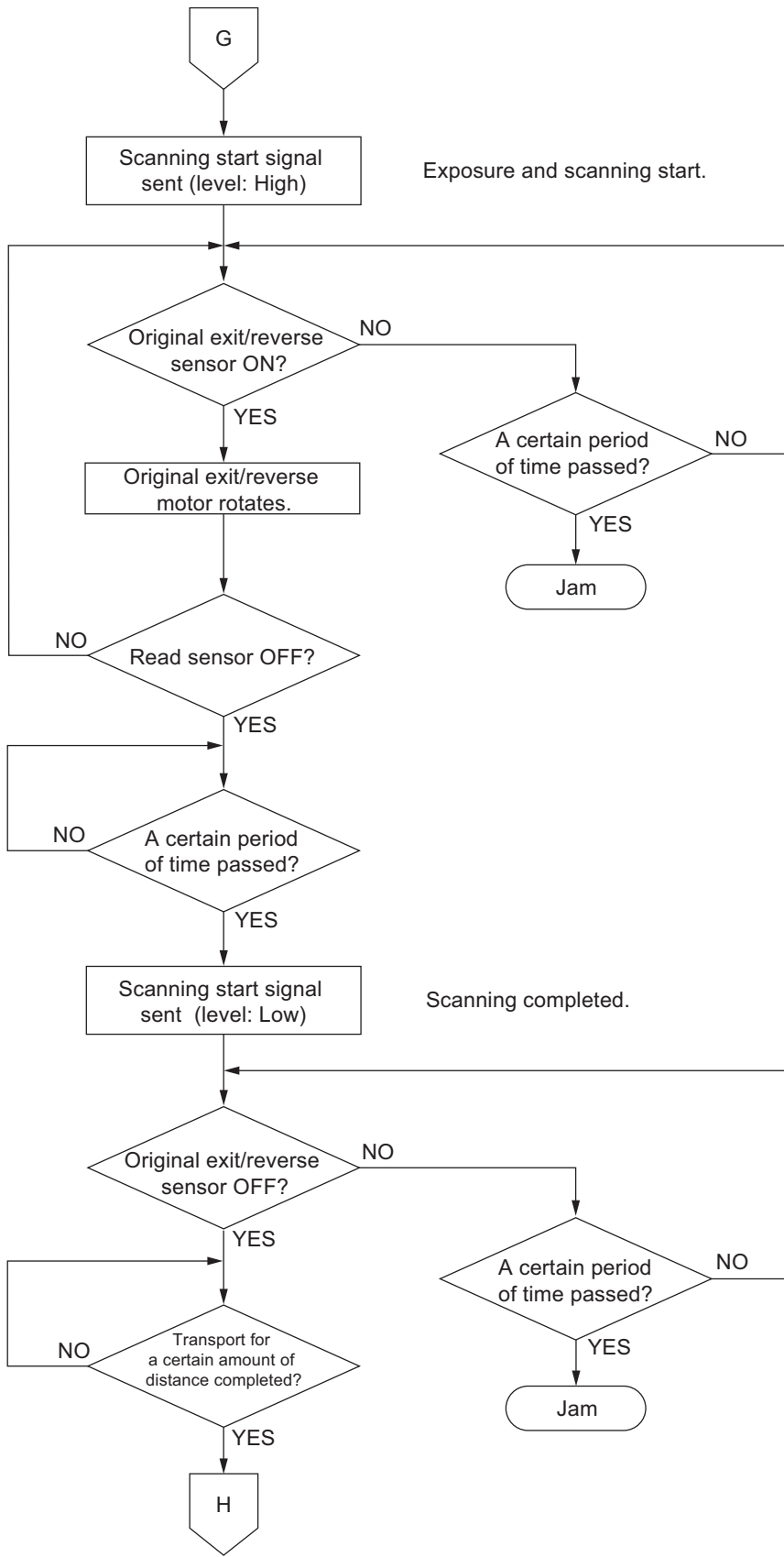

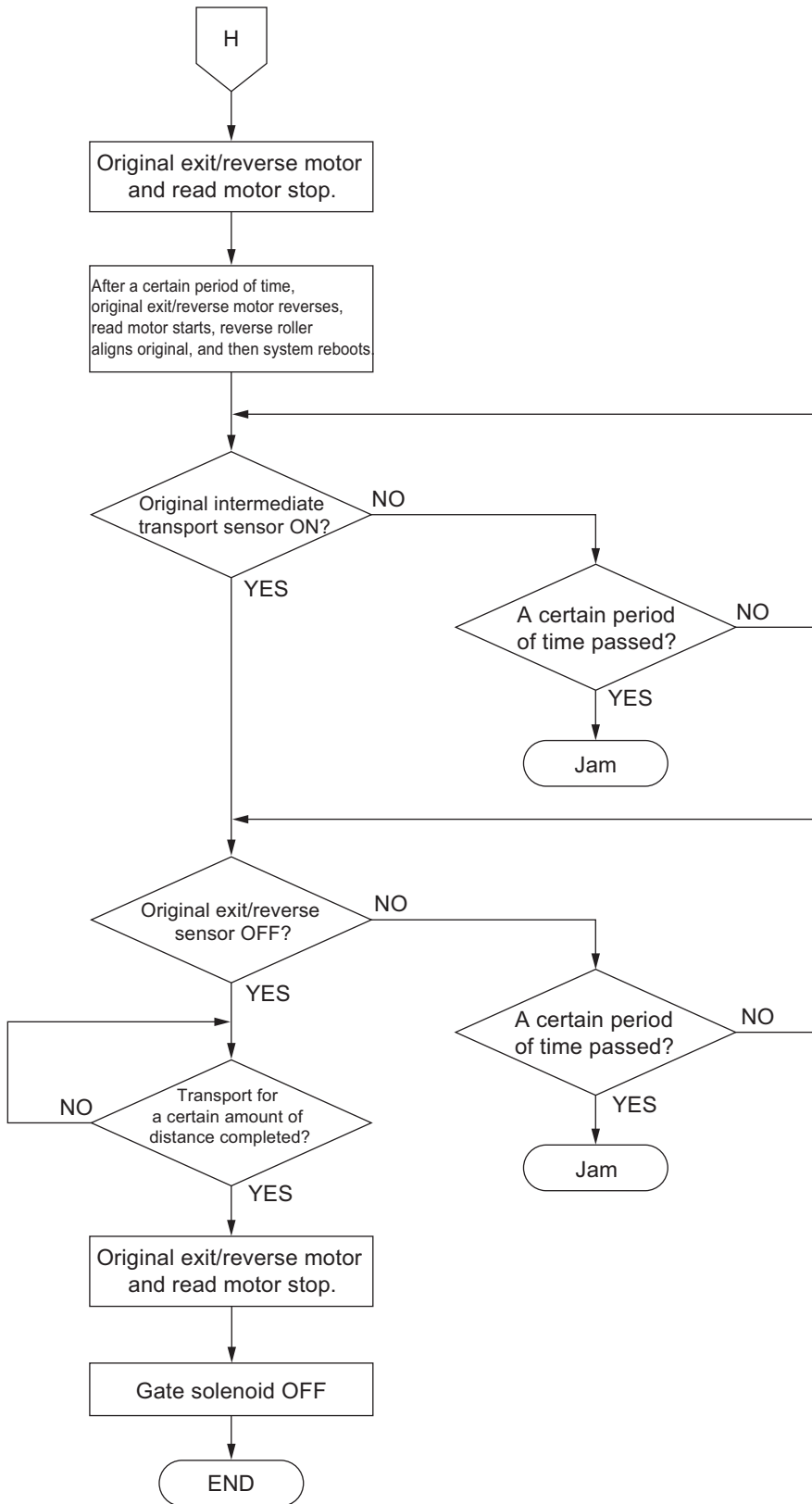

3.4 DESCRIPTION OF CIRCUIT

3.4.1 Drive Circuit for Feed Motor

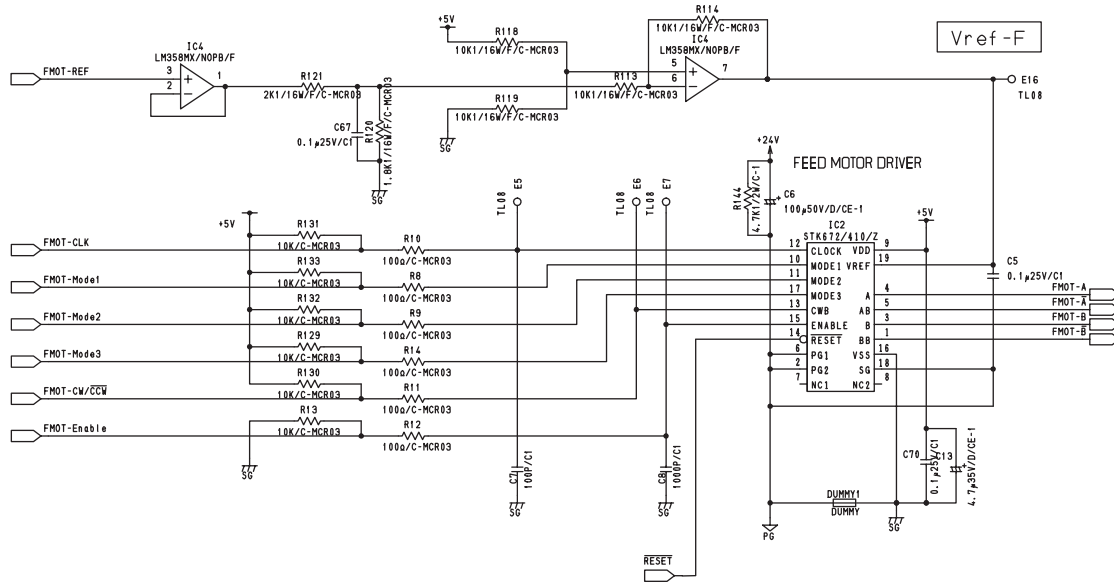

Fig.3-6

This circuit controls the rotation/stoppage and the direction of rotation, excitation mode and motor current of the feed motor.

A drive clock signal (FMOT-CLK) and rotation direction signal (FMOT-CW/CCW) are input to control the speed and direction of the motor rotation.

When the level of the enabling signal (FMOT-Enable) is set to "L", motor current is turned OFF regardless of the state of other signals.

For the excitation mode, either of 2 phase excitation, 1-2 phase excitation, W1-2 phase excitation, 2W1-2 phase excitation or the 4W1-2 phase excitation can be selected using the excitation switching signal (FMOT-Mode1/FMOT-Mode2).

The edge switching signal (FMOT-Mode3) is used to specify the switching timing for excitation phase either from when both the rise and decay edge of the CLK input are detected or when only the rising edge is detected.

Motor current value can be set discretionary by changing the level of the reference setting signal (FMOT-REF).

3.4.2 Drive Circuit for Read Motor

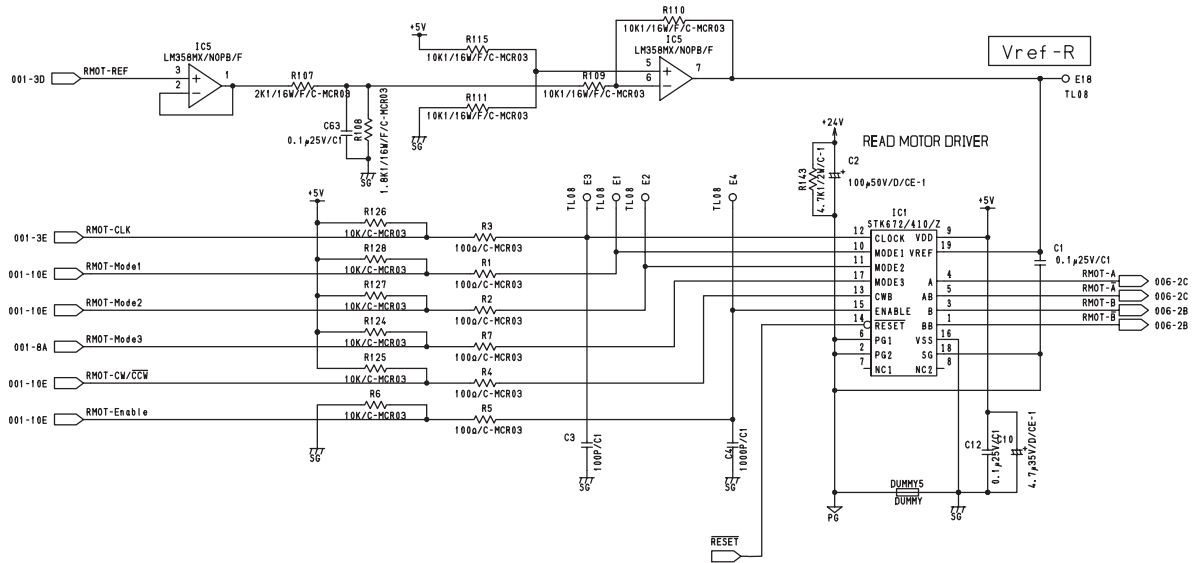

Fig.3-7

This circuit controls the rotation/stoppage and the direction of rotation, excitation mode and motor current of the read motor.

A drive clock signal (RMOT-CLK) and rotation direction signal (RMOT-CW/CCW) are input to control the speed and direction of the motor rotation.

When the level of the enabling signal (RMOT-Enable) is set to "L", motor current is turned to OFF regardless of the state of other signals.

For the excitation mode, either of 2 phase excitation, 1-2 phase excitation, W1-2 phase excitation, 2W1-2 phase excitation or the 4W1-2 phase excitation can be selected using the excitation switching signal (RMOT-Mode1/RMOT-Mode2).

The edge switching signal (RMOT-Mode3) is used to specify the switching timing for excitation phase either from when both the rise and decay edge of the CLK input are detected or when only the rising edge is detected.

Motor current value can be set discretionarily by changing the level of the reference setting signal (RMOT-REF).

3.4.3 Drive Circuit for Exit Motor

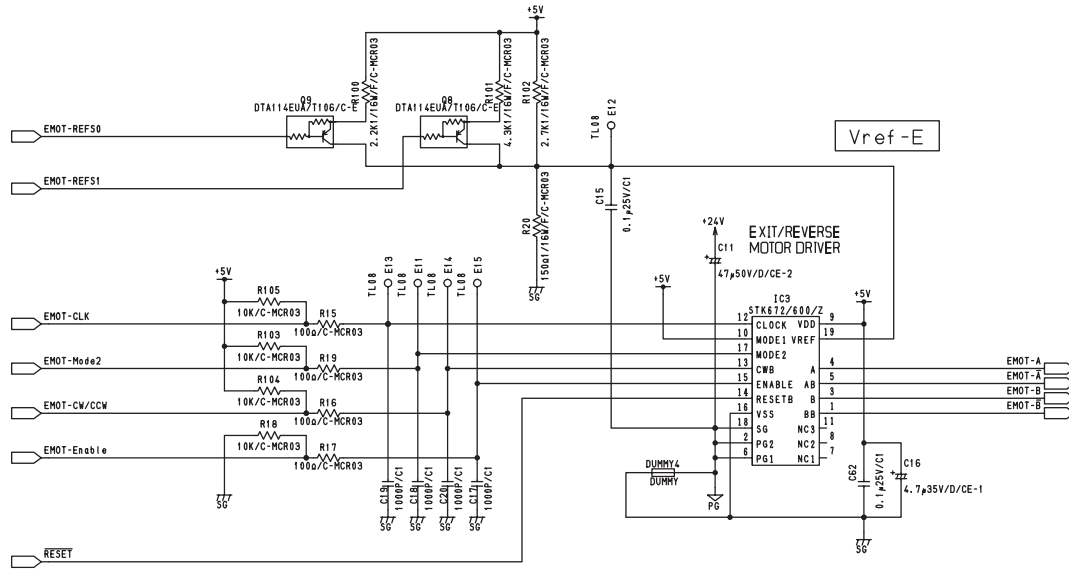

Fig.3-8

This circuit controls the rotation/stoppage and the direction of rotation, excitation mode and motor current of the exit motor.

A drive clock signal (EMOT-CLK) and rotation direction signal (EMOT-CW/CCW) are input to control the speed and direction of the motor rotation.

When the level of the enabling signal (EMOT-Enable) is set to "L", motor current is turned OFF regardless of the state of other signals.

As IC3-10pin (MODE1) is connected to +5V, excitation mode is applied at 1-2 phase excitation.

The edge switching signal (EMOT-Mode3) is used to specify the switching timing for excitation phase either from when both the rise and decay edge of the CLK input are detected or when only the rising edge is detected.

Motor current value can be set discretely by switching the level of the reference switching signal (EMOT-REFS0,EMOT-REFS1).

3.4.4 Drive Circuit for FAN Motor

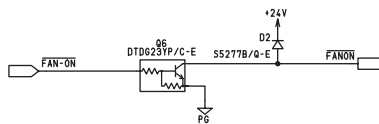

Fig.3-9

This circuit controls the rotation/stoppage of the fan motor. The FAN starts to rotate when the FAN motor drive signal level is set to "H", and stops when the level is set to "L".

3.4.5 Reset Circuit

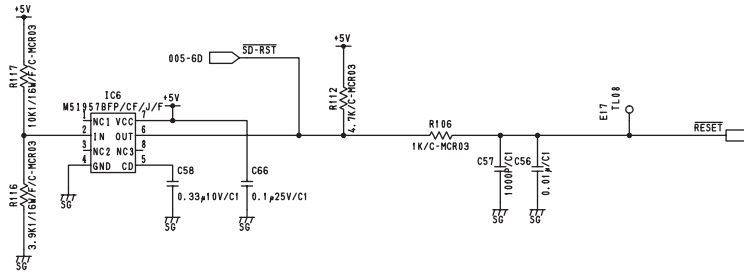

Fig.3-10

This circuit generates a reset signal when the power is turned ON and the power voltage is blocked or cut off/lowered temporarily.

At the power-ON, the circuit shifts the level of the reset signal from “L” to “H” to put the CPU in a operative state after the reset pulse duration (T_{pd}) determined by the capacitance of C58 has passed from when the power voltage has reached the supervisory voltage (V_s) divided by R116 and R117.

When a power voltage drop (cutoff, temporary cutoff, temporary low voltage) occurs and the power voltage becomes lower than the set value for the supervisory voltage for the power, the circuit sets the level of the reset signal ($\overline{\text{RESET}}$) to “L” to put the CPU in a halt state.

3.4.6 Drive Circuit for Pickup Solenoid

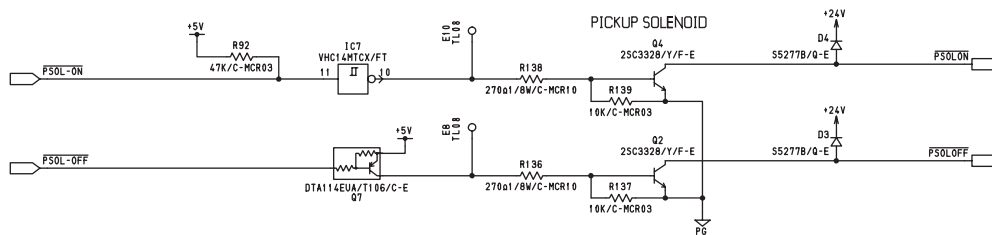

Fig.3-11

Pick up solenoid is a two-way solenoid that can be operated both in suction and recovery, and driven by two transistors (Q4 and Q2) for each operation respectively.

When the PSOL-ON-Signal level is set to “L”, Q4 is turned ON, the power of 24V is applied to the coil for suction operation, the solenoid is turned ON, and then the pickup roller goes down.

When the PSOL-ON-Signal level is set to “L”, Q2 is turned ON, the power of 24V is applied to the coil for recovery operation, the solenoid is turned OFF, and then the pickup roller goes up.

3.4.7 Drive Circuit for Gate Solenoid

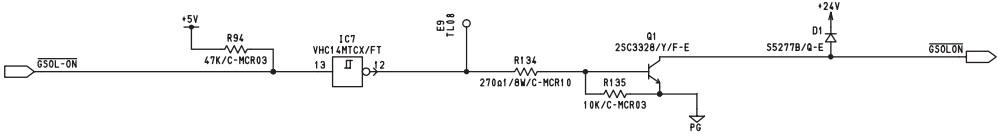

Fig.3-12

Gate solenoid driven by the driver transistor (Q1) is a solenoid which is used to switch an original into the reverse tray when in the duplex scanning mode. When the GSOL-ON-Signal level is set to "L", the reverse flapper goes down and the original is transported to the reverse tray.

4. DISASSEMBLY AND ASSEMBLY

4.1 Cover

[A] Front cover

- (1) Open the RADF and remove 3 screws.

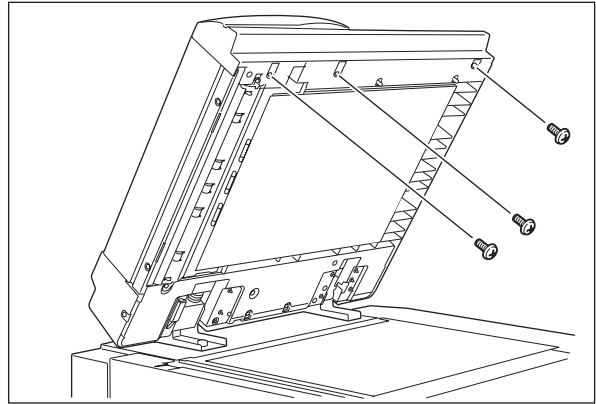

Fig.4-1

- (2) Close the RADF.
- (3) Open the jam access cover and remove 2 screws.

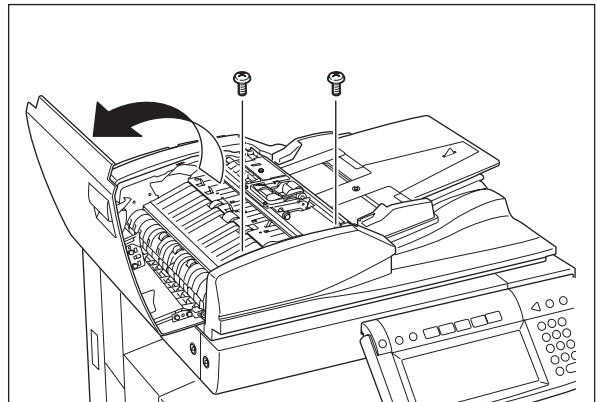

Fig.4-2

- (4) Take off the front cover toward you.

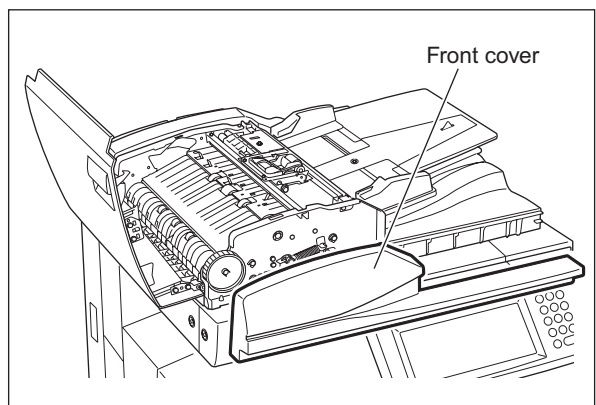

Fig.4-3

[B] Rear cover

- (1) Open the jam access cover and remove 4 screws.

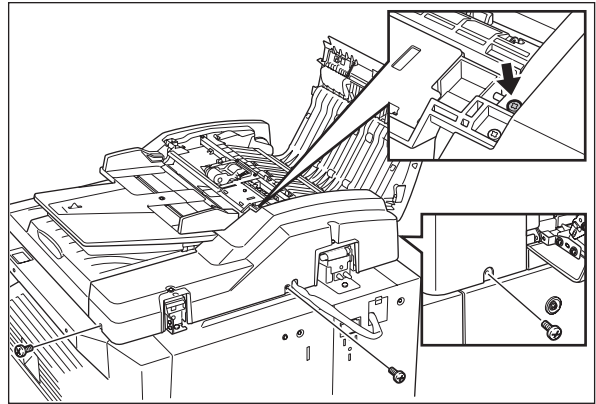

Fig.4-4

- (2) Raise the original tray and take off the rear cover upward.

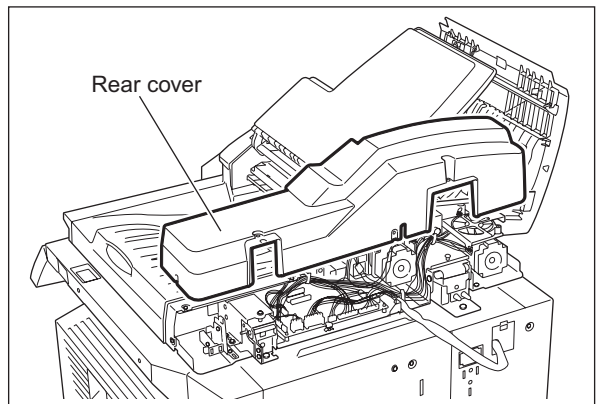

Fig.4-5

[C] Jam access cover

- (1) Take off the front cover.
(📖 P.4-1 "[A] Front cover")
- (2) Take off the rear cover.
(📖 P.4-2 "[B] Rear cover")
- (3) Remove 1 clip and then the dial and pin.

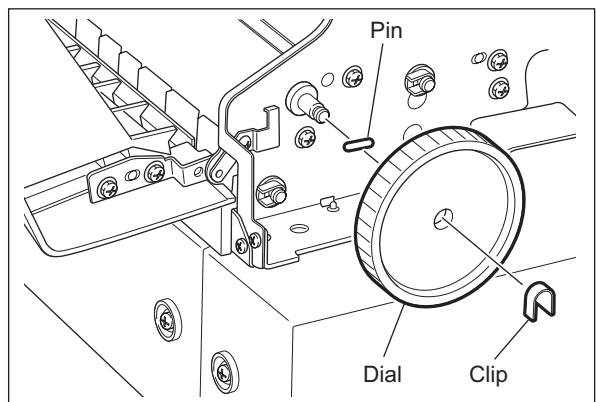

Fig.4-6

(4) Remove 1 screw and the hinge pin.

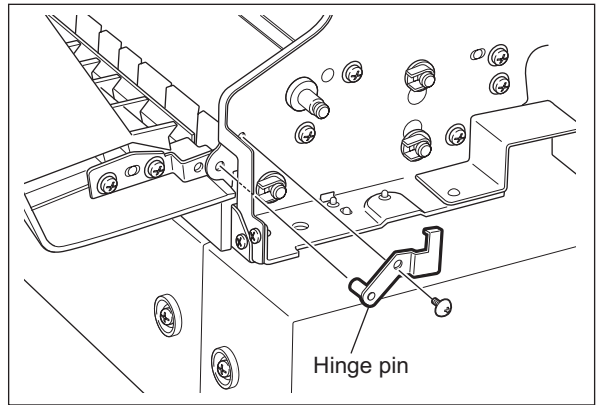

Fig.4-7

(5) Take off the jam access cover by sliding it.

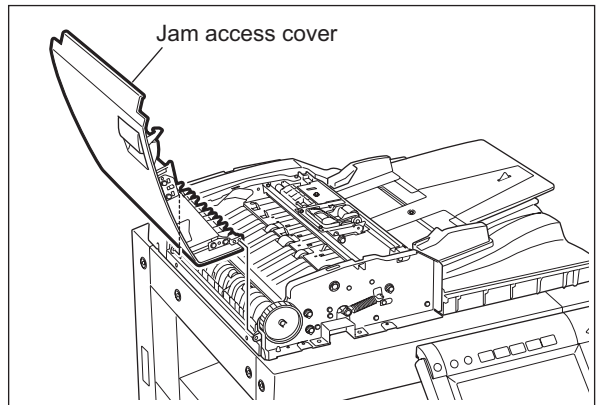

Fig.4-8

[D] Left cover

(1) Remove 2 screws and take off the left cover.

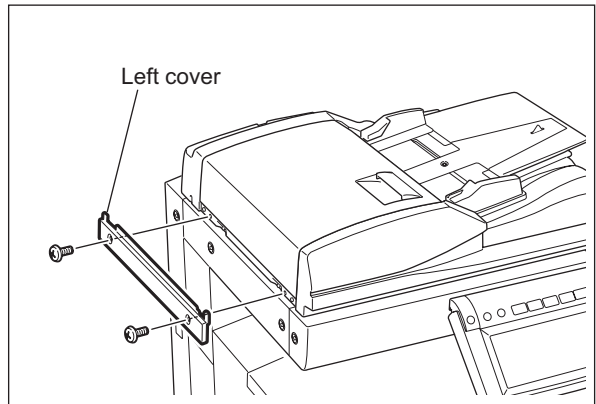

Fig.4-9

[E] Original tray

- (1) Take off the front cover.
(☞ P.4-1 "[A] Front cover")
- (2) Take off the rear cover.
(☞ P.4-2 "[B] Rear cover")
- (3) Take off the paper feeder unit.
(☞ P.4-6 "[A] Paper feeder unit")
- (4) Remove 2 screws. Lift up the feeder upper guide by sliding it to the right.

Note:

Do not pull the harness too strong.

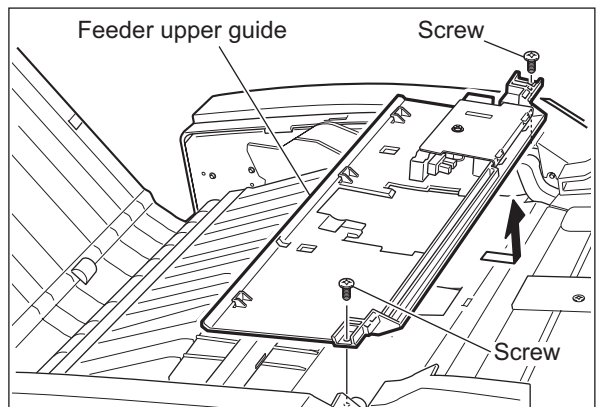

Fig.4-10

- (5) Disconnect 1 connector from the RADF control PC board.

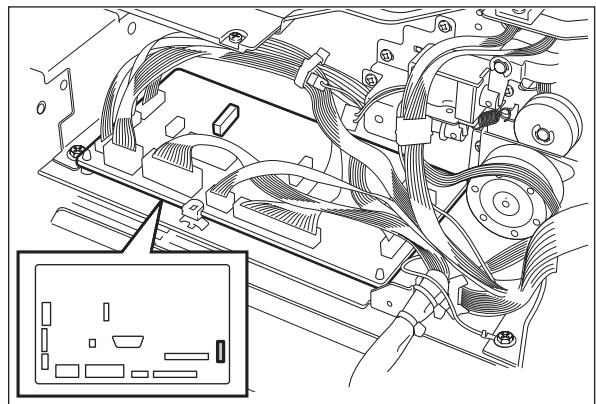

Fig.4-11

- (6) Remove 1 screw and take off the bushing.
- (7) Take off the original tray.

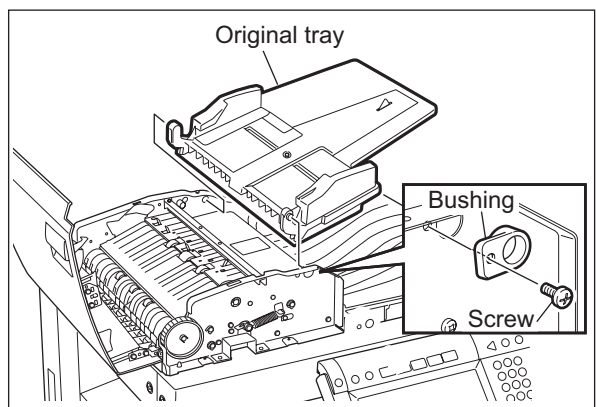



Fig.4-12

[F] Original reverse tray

- (1) Take off the original tray.
( P.4-4 "[E] Original tray")
- (2) Remove 1 screw and take off the original reverse tray.

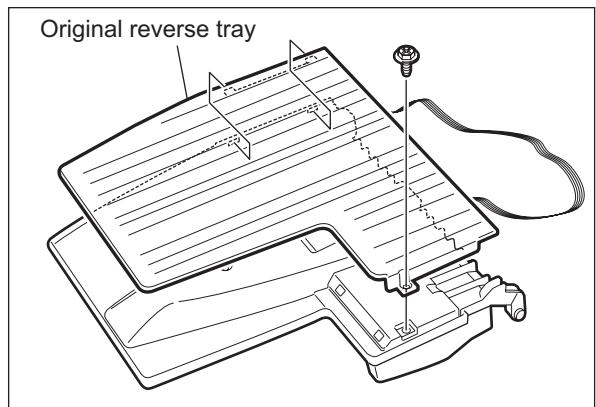

Fig.4-13

4.2 Roller

[A] Paper feeder unit

- (1) Open the jam access cover.
- (2) Remove 2 screws and take off the bracket.

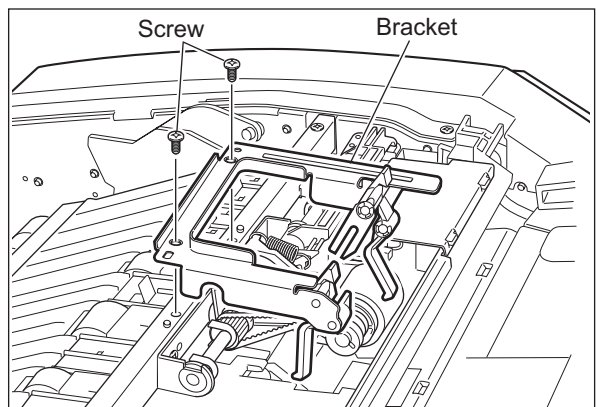

Fig.4-14

- (3) Remove 1 clip and slide 2 bushings.

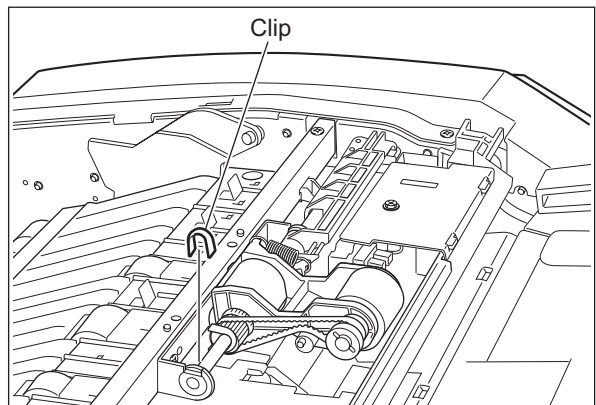

Fig.4-15

- (4) Take off the paper feeder unit.

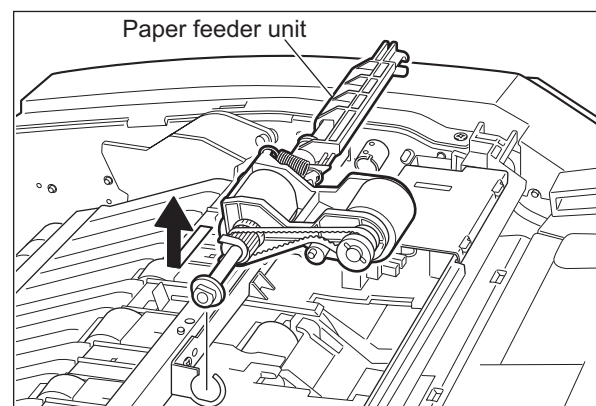

Fig.4-16

[B] Pickup roller [PM]

- (1) Take off the paper feeder unit.
(📖 P.4-6 "[A] Paper feeder unit")
- (2) Remove 1 clip and pull out the shaft. Take off the pickup roller.

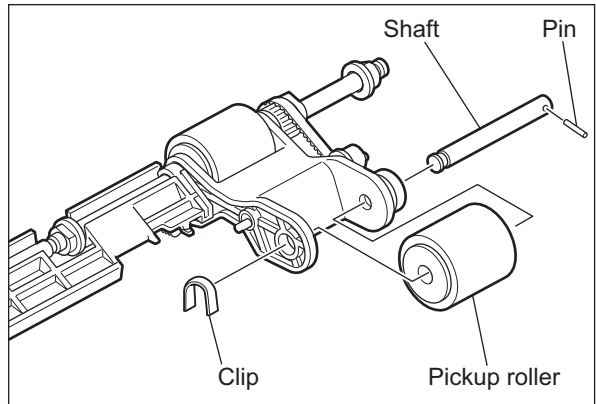

Fig.4-17

Notes:

1. Be careful not to drop the pin because it will come off when the shaft is pulled out.
2. Make sure you assemble the pickup roller with the one-way clutch in the correct direction.

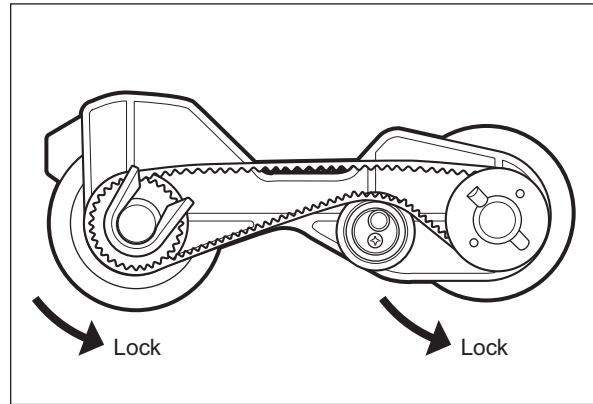

Fig.4-18

[C] Feed roller [PM]

- (1) Take off the paper feeder unit.
(📖 P.4-6 "[A] Paper feeder unit")
- (2) Remove 1 clip.

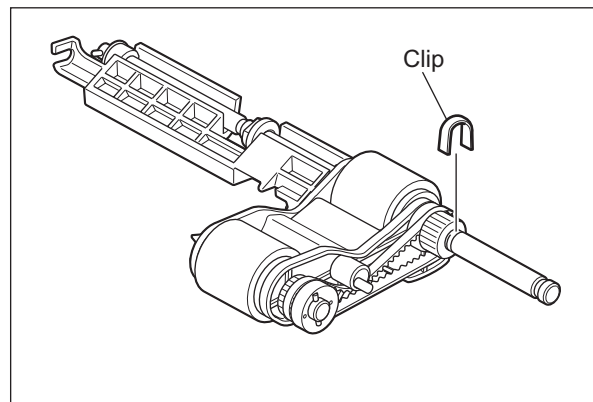

Fig.4-19

(3) Slide the pulley and remove 1 pin.

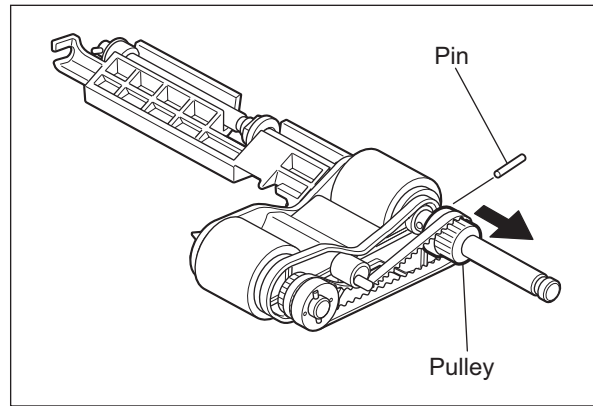

Fig.4-20

(4) Pull out the shaft and take off the feed roller.

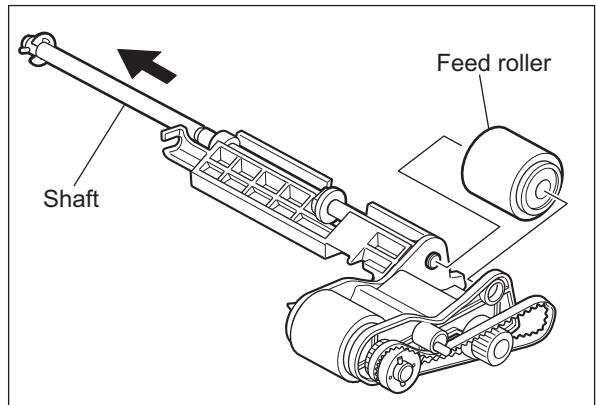

Fig.4-21

Note:

Make sure you assemble the feed roller with the one-way clutch in the correct direction.

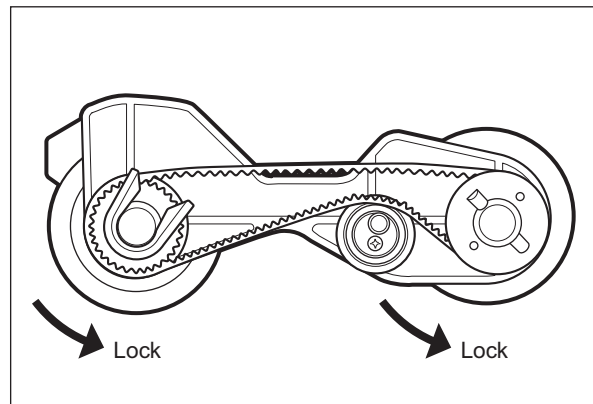

Fig.4-22

[D] Separation roller [PM]

- (1) Take off the paper feeder unit.
(P.4-6 "[A] Paper feeder unit")
- (2) Remove 2 screws. Slide the feeder upper guide to the right and raise it.

Note:

Do not pull the harness out with too much force.

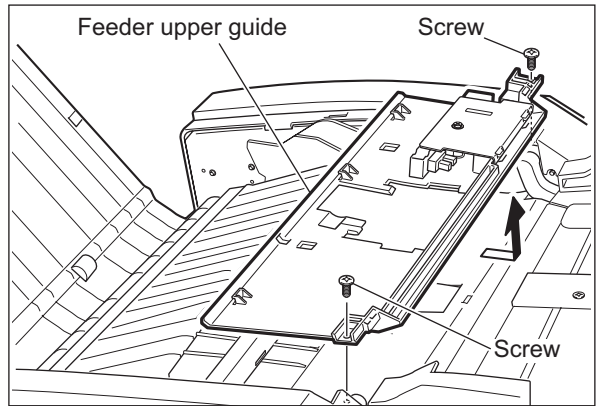

Fig.4-23

- (3) Remove 2 screws and take off the separation roller holder and separation roller unit.

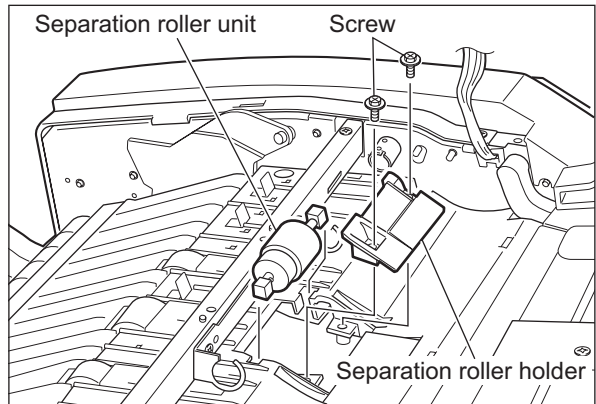

Fig.4-24

- (4) Remove 1 bushing and clip, and then take off the separation roller.

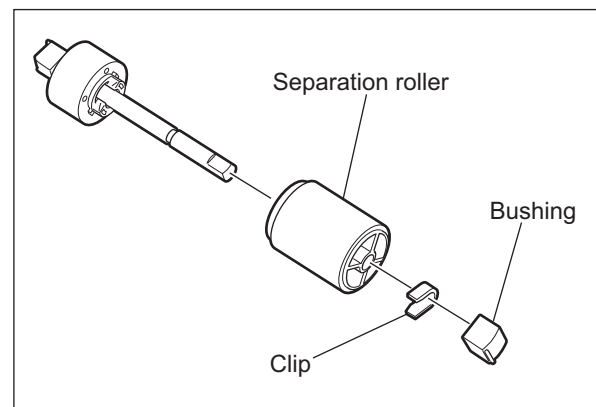

Fig.4-25

[E] Feeder lower guide

- (1) Take off the original tray.
(📖 P.4-4 "[E] Original tray")
- (2) Take off the paper feeder unit.
(📖 P.4-6 "[A] Paper feeder unit")
- (3) Remove 2 screws and take off the stay.

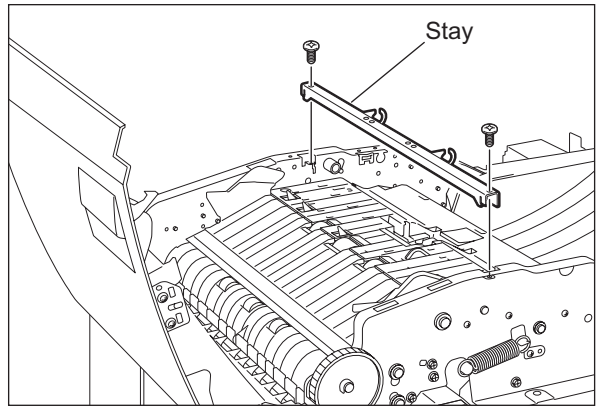

Fig.4-26

- (4) Take off the jam access guide.

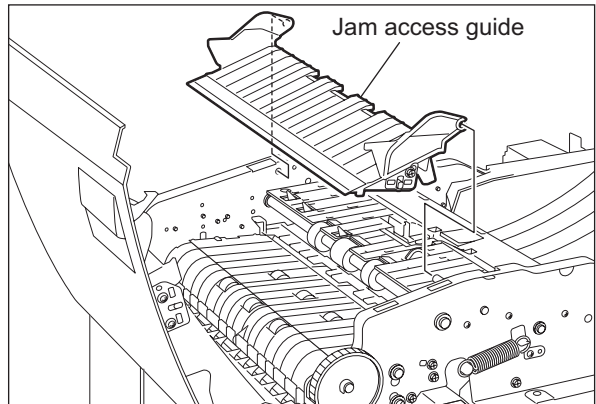

Fig.4-27

- (5) Remove 4 screws. Disconnect 1 connector and take off the feeder lower guide.

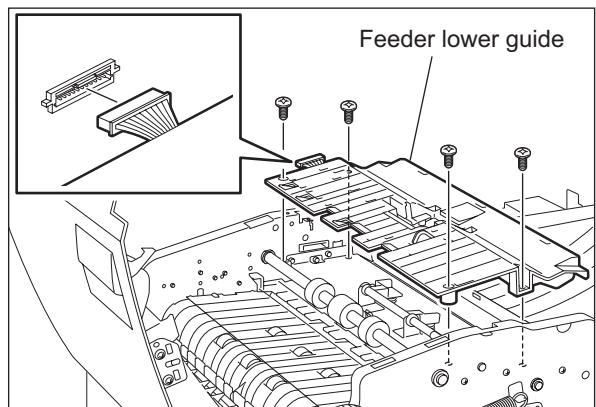

Fig.4-28

[F] Registration roller

- (1) Take off the feeder lower guide.
(☞ P.4-10 "[E] Feeder lower guide")
- (2) Take off the original feed motor drive section.
(☞ P.4-21 "[E] Original feed motor drive section")
- (3) Remove 1 E-ring and 1 bushing from the front side of the registration roller shaft. Also, remove 1 bushing, 1 pulley, 1 E-ring and 1 bushing from the rear side of the shaft, and then take off the registration roller.

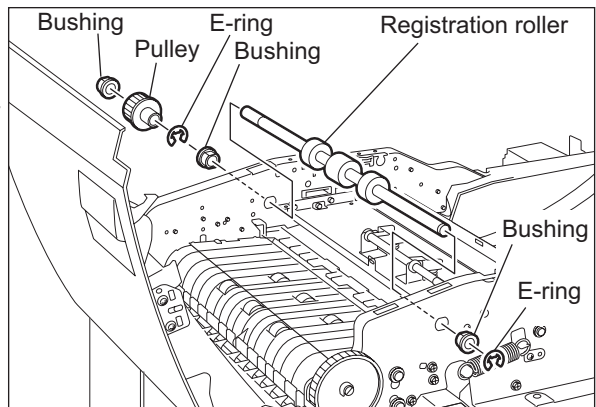

Fig.4-29

[G] Exit/reverse roller

- (1) Take off the front cover.
(☞ P.4-1 "[A] Front cover")
- (2) Take off the original exit/reverse motor.
(☞ P.4-23 "[F] Original exit/reverse motor (M3)")
- (3) Remove 1 clip, 1 pulley, 1 pin and 1 bushing from the rear side of the exit/reverse roller shaft.

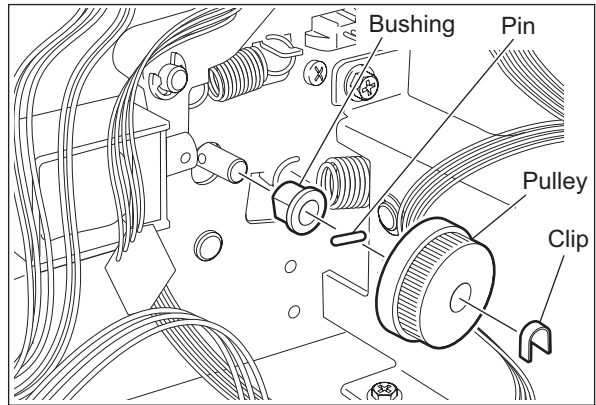

Fig.4-30

- (4) Remove 1 screw and take off the leaf spring.
- (5) Remove 1 clip and 1 bushing from the front side of the exit/reverse roller shaft.

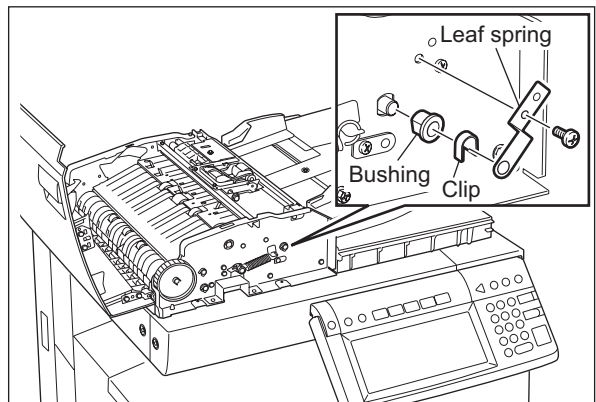

Fig.4-31

(6) Take off the jam access guide.

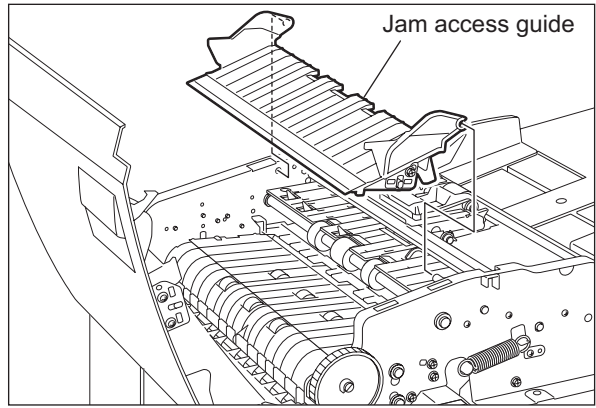

Fig.4-32

(7) Pull out the exit guide.

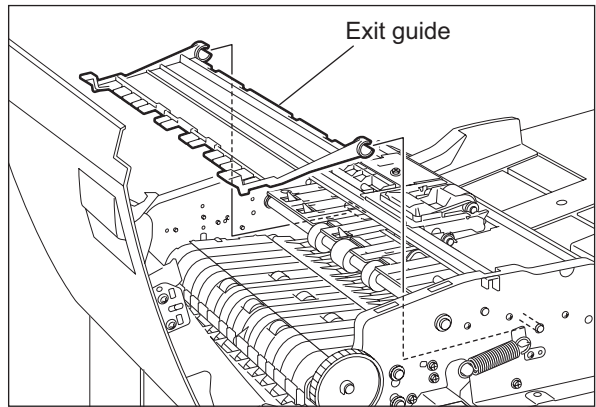

Fig.4-33

(8) Take off the exit/reverse roller.

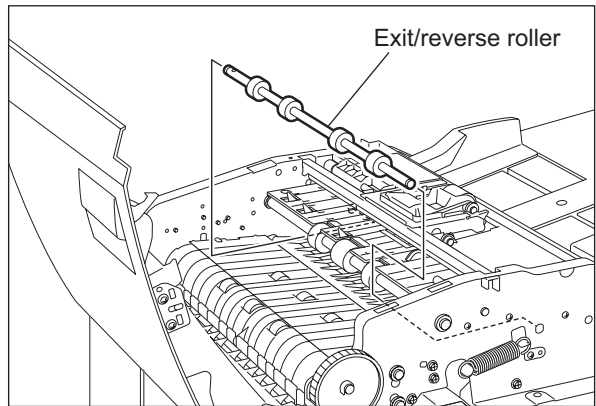

Fig.4-34

[H] Pre-reading lower guide / pre-reading upper guide

- (1) Take off the front cover.
(📖 P.4-1 "[A] Front cover")
- (2) Take off the rear cover.
(📖 P.4-2 "[B] Rear cover")
- (3) Take off the jam access cover.
(📖 P.4-2 "[C] Jam access cover")
- (4) Take off the left cover.
(📖 P.4-3 "[D] Left cover")
- (5) Remove 4 screws and take off the pre-reading lower guide.

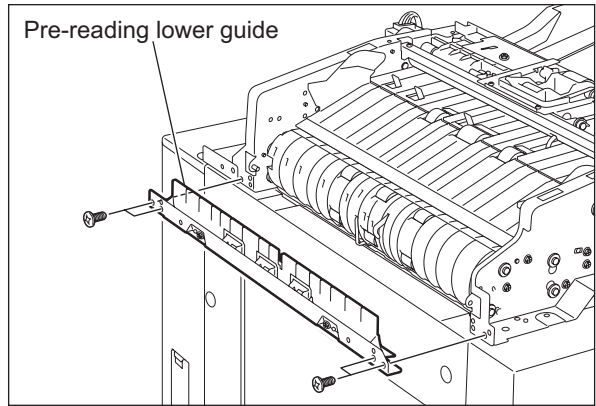

Fig.4-35

- (6) Disconnect 2 connectors. Remove 2 screws and take off the pre-reading upper guide.

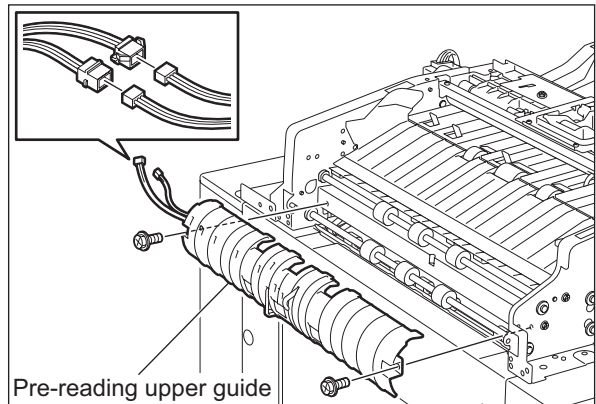

Fig.4-36

[I] Intermediate transport roller

- (1) Take off the pre-reading upper guide.
(📖 P.4-13 "[H] Pre-reading lower guide / pre-reading upper guide")
- (2) Take off the read motor drive section.
(📖 P.4-19 "[C] Read motor drive section")
- (3) Remove 1 bushing, 1 E-ring, 1 pulley, 1 pin and 1 bushing from the rear side of the intermediate transport roller shaft.
- (4) Remove 1 bushing from the front side of the intermediate transport roller shaft.
- (5) Take off the intermediate transport roller.

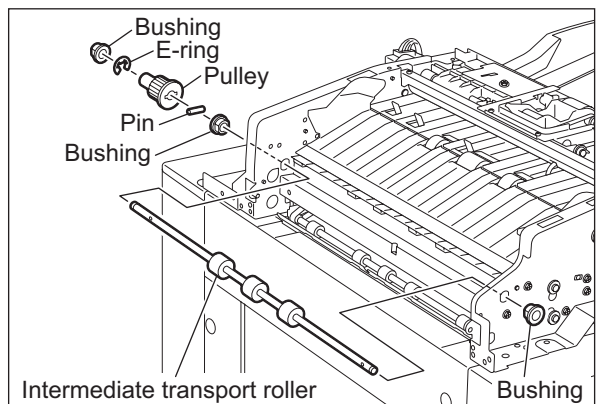

Fig.4-37

[J] Pre-reading roller

- (1) Take off the pre-reading upper guide.
(P.4-13 "[H] Pre-reading lower guide / pre-reading upper guide")
- (2) Take off the read motor drive section.
(P.4-19 "[C] Read motor drive section")
- (3) Remove 1 bushing and 1 E-ring from the rear side of the pre-reading roller shaft. Loosen 2 setscrews and take off 1 flange. Then take off 1 pulley and 1 bearing.

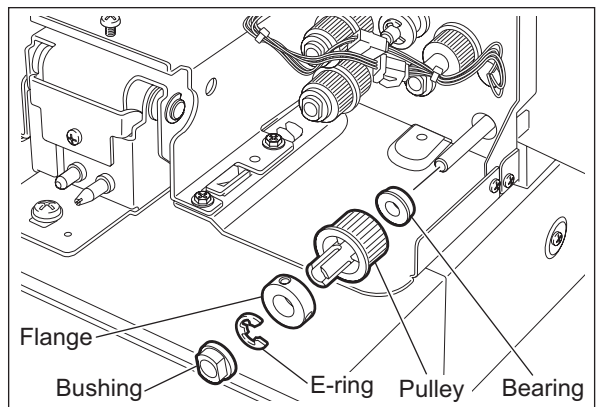

Fig.4-38

- (4) Remove 1 clip and 1 bushing from the front side of the pre-reading roller shaft.
- (5) Take off the pre-reading roller.

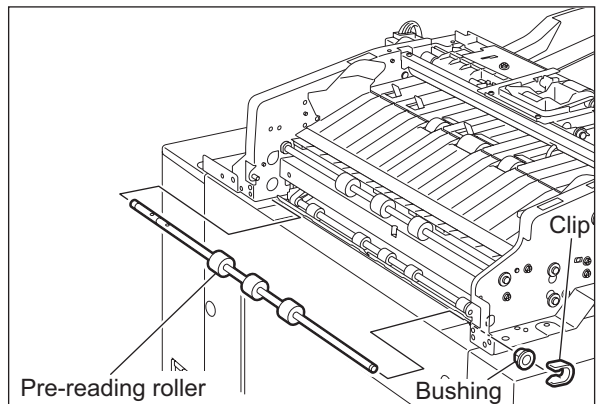

Fig.4-39

[K] Platen roller / post-reading roller

- (1) Take off the pre-reading lower guide.
(P.4-13 "[H] Pre-reading lower guide / pre-reading upper guide")
- (2) Disconnect 1 connector.

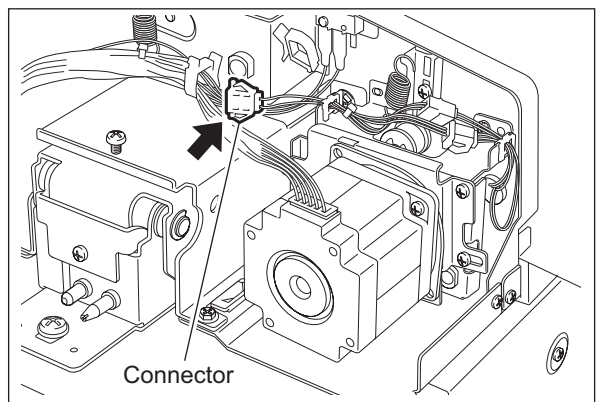

Fig.4-40

- (3) Take off the read motor drive section.
(P.4-19 "[C] Read motor drive section")
- (4) Remove 1 bushing, 1 E-ring and 1 pulley from the rear side of the post-reading roller shaft. Loosen 2 setscrews and take off 1 flange. Take off 1 bearing.

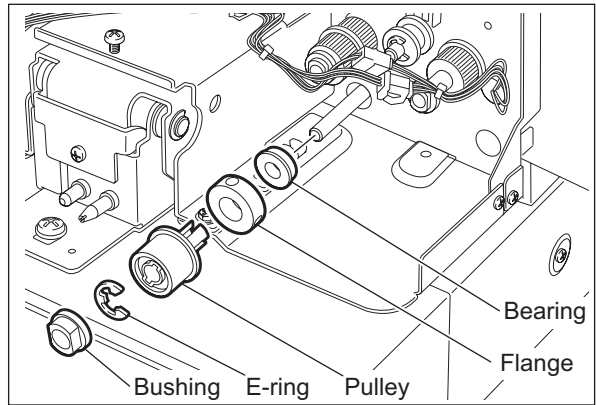

Fig.4-41

- (5) Remove 1 clip and 1 bushing from the front side of the post-reading roller shaft.

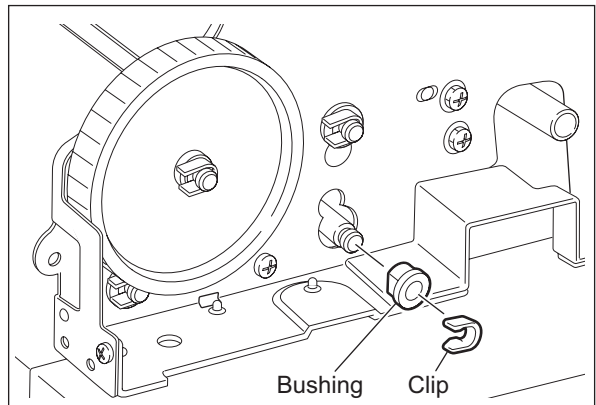

Fig.4-42

- (6) Open the RADF. Remove 4 screws, take off 2 holders and platen guide.

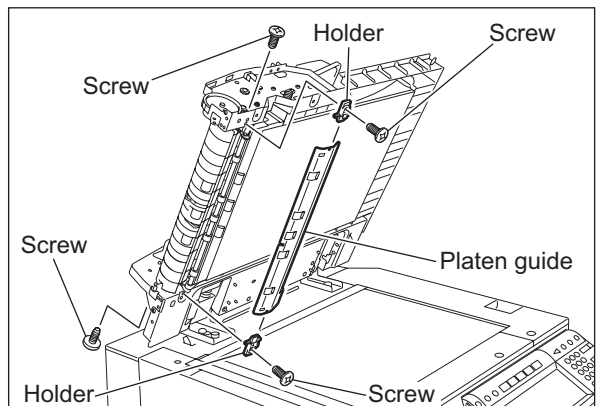

Fig.4-43

- (7) Remove 2 screws. Open the post-reading lower guide and take off the post-reading upper guide.

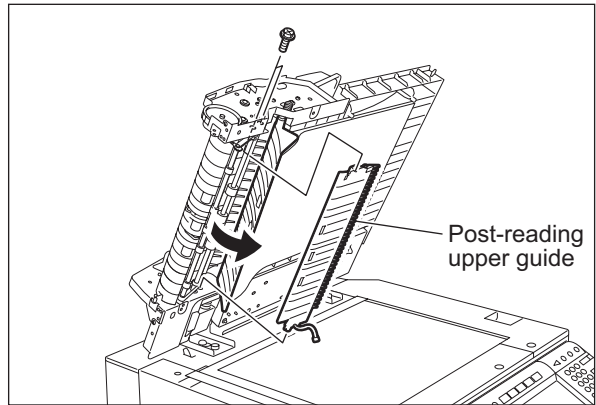

Fig.4-44

- (8) Take off the platen roller and post-reading roller.

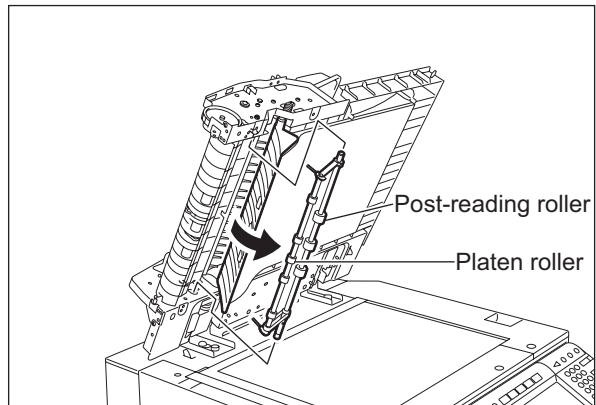

Fig.4-45

[L] Reverse registration roller

- (1) Take off the platen roller and post-reading roller.
(P.4-14 "[K] Platen roller / post-reading roller")
- (2) Remove 1 E-ring, 1 pulley, 1 pin and 1 bushing from the rear side of the reverse registration roller shaft.

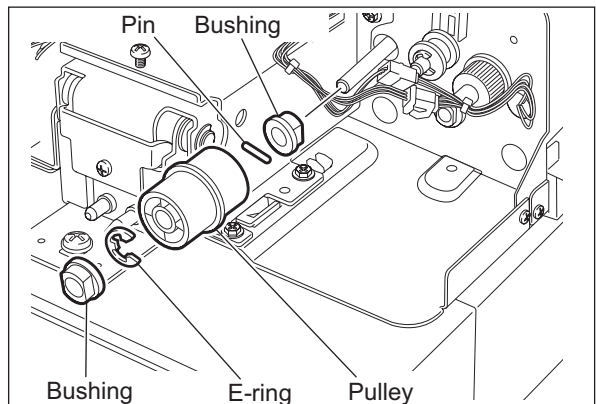

Fig.4-46

- (3) Remove 1 clip and 1 bushing from the front side of the reverse registration roller shaft.

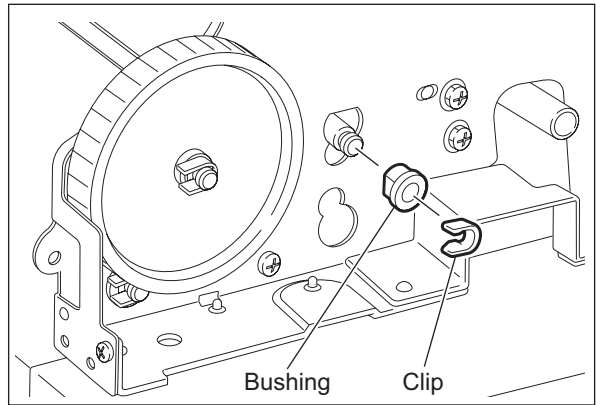

Fig.4-47

- (4) Open the RADF. Take off the reverse registration roller.

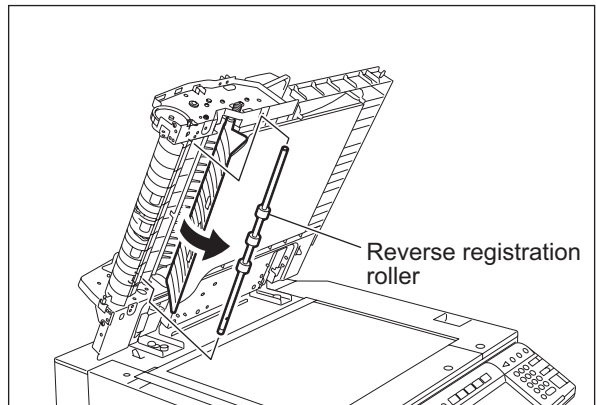



Fig.4-48

4.3 Motor / Motor drive section

[A] Fan motor (M4)

- (1) Take off the rear cover.
( P.4-2 "[B] Rear cover")
- (2) Disconnect 1 connector. Then remove 2 screws to take off the fan motor.

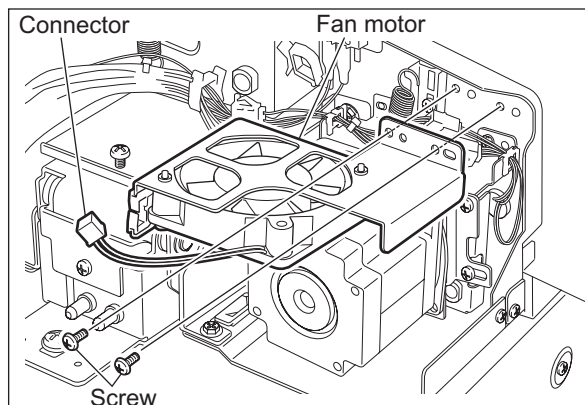



Fig.4-49

[B] Read motor (M2)

- (1) Take off the rear cover.
( P.4-2 "[B] Rear cover")
- (2) Take off the fan motor.
( P.4-18 "[A] Fan motor (M4)")
- (3) Disconnect 1 connector. Then remove 2 screws to take off the read motor.

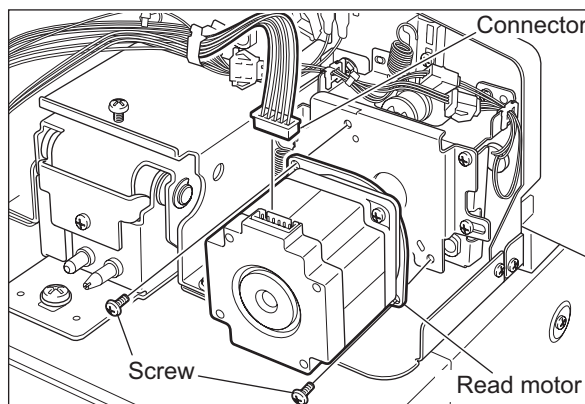

Fig.4-50

[C] Read motor drive section

- (1) Take off the rear cover.
(P.4-2 "[B] Rear cover")
- (2) Take off the fan motor.
(P.4-18 "[A] Fan motor (M4)")
- (3) Disconnect 1 connector, and then remove 1 spring. (Spring: Outside diameter of coil – $\varnothing 10.2$ mm, active coils – 12.5)

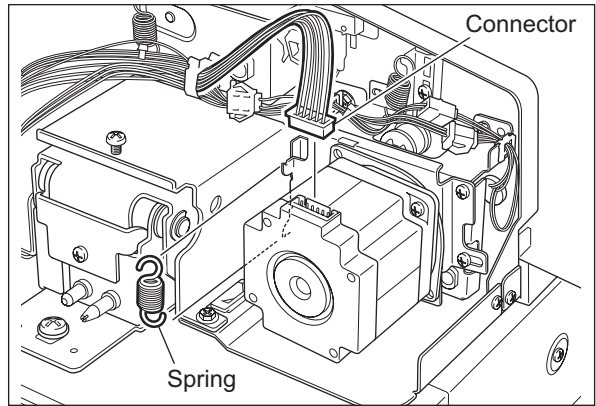

Fig.4-51

- (4) Remove 3 screws, and then take off the read motor with its bracket.

Note:

When the unit is being assembled, temporarily tighten the screws removed at step (3), and then attach the spring removed at step (2). Then fully tighten these screws.

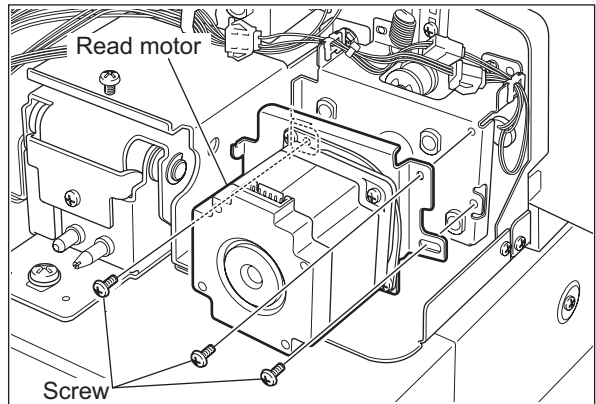

Fig.4-52

- (5) Remove 1 spring. (Spring: Outside diameter of coil – $\varnothing 8.8$ mm, active coils – 12.5)
- (6) Release the harness from 2 harness clamps.

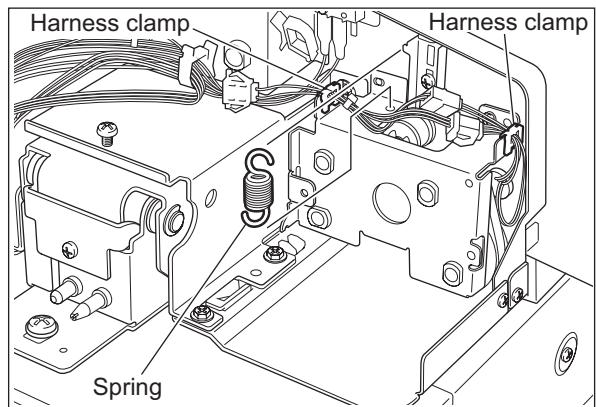

Fig.4-53

- (7) Remove 3 screws and then take off the bracket.

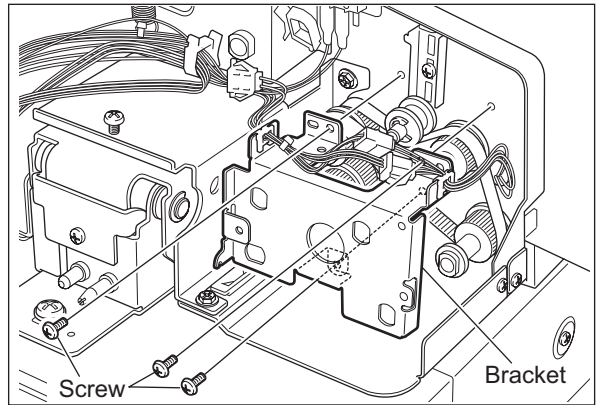

Fig.4-54

- (8) Take off 1 timing belt and 4 bushings.

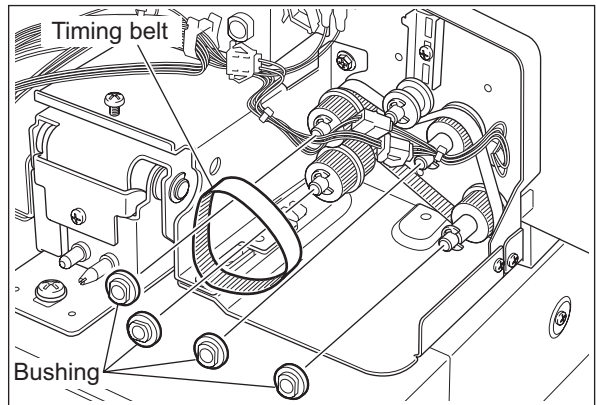

Fig.4-55

- (9) Loosen 1 screw of the belt tensioner.
(10) Remove the E-ring, and then take off the pulley and timing belt.

Note:

When the unit is being assembled, first install the parts removed at steps (5), (6), (7) and (9), and attach the spring removed at step (4) next. Then tighten the screw loosened at step (8).

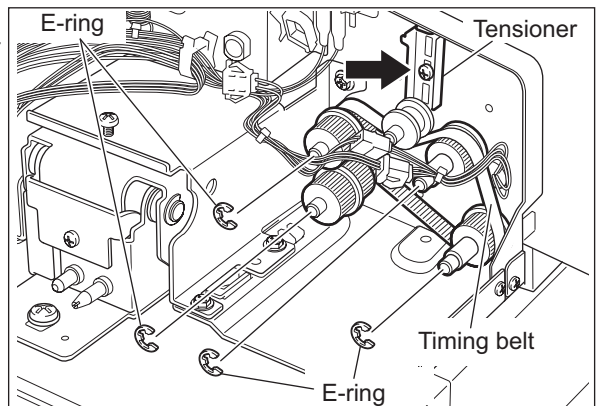

Fig.4-56

[D] Original feed motor (M1)

- (1) Take off the rear cover.
(P.4-2 "[B] Rear cover")
- (2) Disconnect 1 connector. Then remove 2 screws to take off the original feed motor.

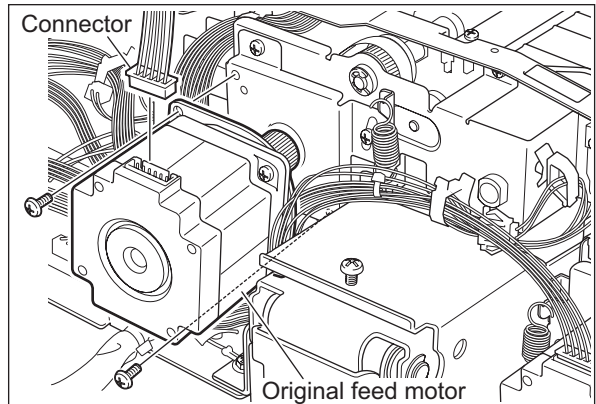

Fig.4-57

[E] Original feed motor drive section

- (1) Take off the rear cover.
(P.4-2 "[B] Rear cover")
- (2) Disconnect 1 connector, and then remove 1 spring. (Spring: Outside diameter of coil – $\varnothing 9.6$ mm, acceptable turns of coil – 12 turns)

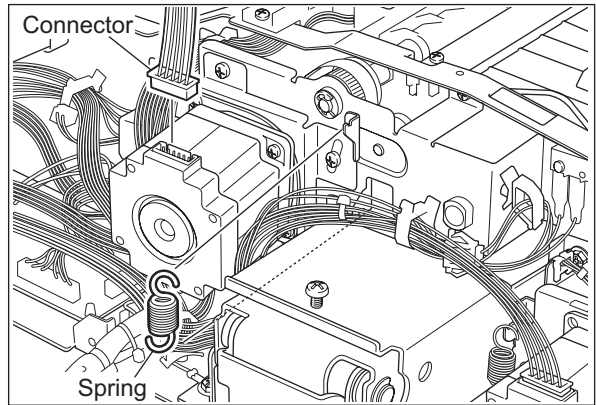

Fig.4-58

- (3) Remove 3 screws, and then take off the original feed motor with its bracket.

Note:

When the unit is being assembled, temporarily tighten the screws removed at step (3) and then attach the spring removed at step (2). Then fully tighten these screws.

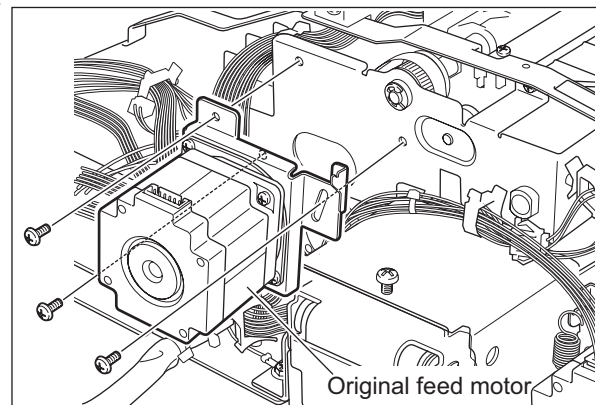

Fig.4-59

- (4) Release the harness from 3 harness clamps.
- (5) Remove 1 E-ring and take off the bushing.

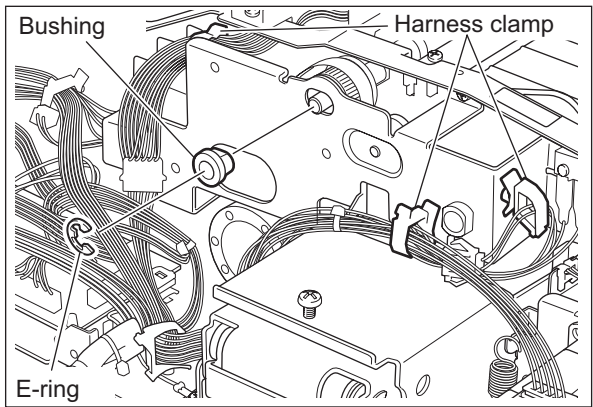

Fig.4-60

- (6) Disconnect 2 terminals of the switch.
- (7) Remove 4 screws, and then take off the bracket.

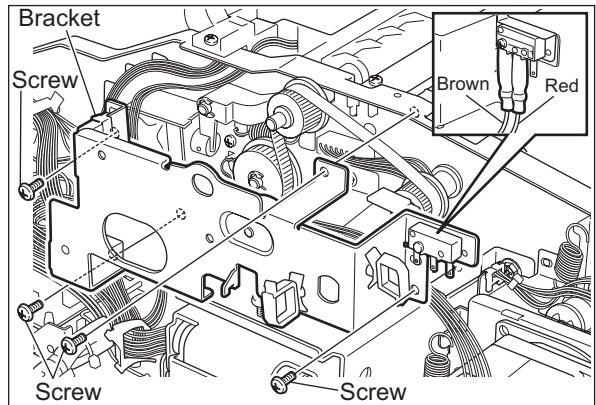

Fig.4-61

- (8) Take off the timing belt, bushings and pulley.

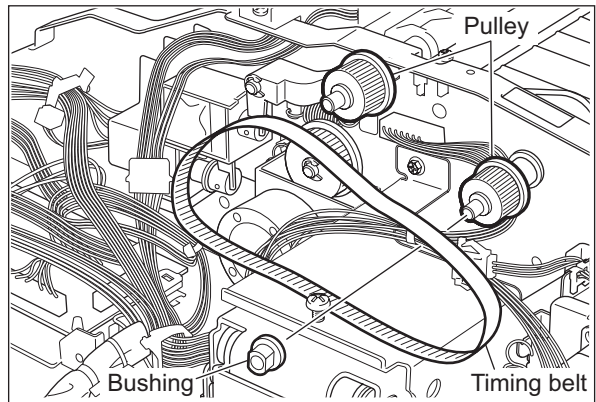



Fig.4-62

[F] Original exit/reverse motor (M3)

- (1) Take off the original feed motor drive section.
( P.4-21 "[E] Original feed motor drive section")
- (2) Disconnect 1 connector from the RADF control PC board.

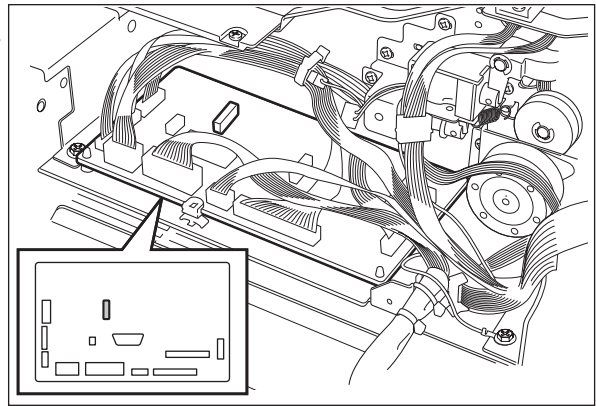

Fig.4-63

- (3) Remove 2 screws, and then take off the original exit/reverse motor with its bracket.

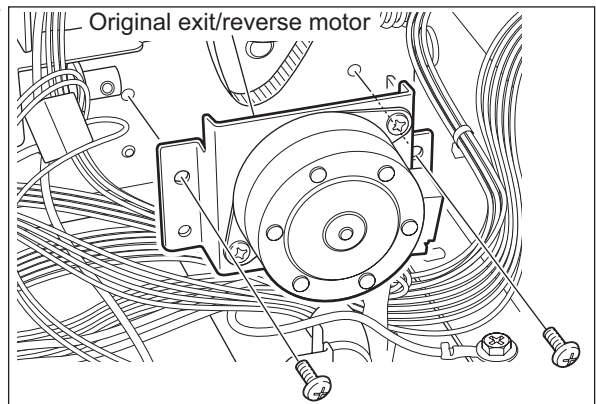

Fig.4-64

- (4) Remove 2 screws, and then take off the original exit/reverse motor by sliding it from the bracket.

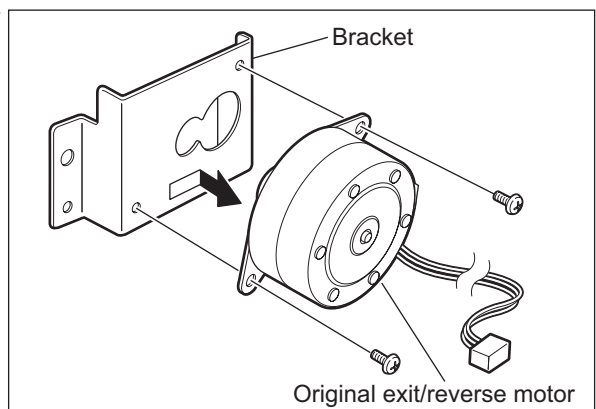

Fig.4-65

4.4 Solenoid

[A] Original pickup solenoid (SOL1)

- (1) Take off the original feed motor drive section. (P.4-21 "[E] Original feed motor drive section")
- (2) Disconnect one connector. Remove 2 screws and take off the original pickup solenoid with the bracket.

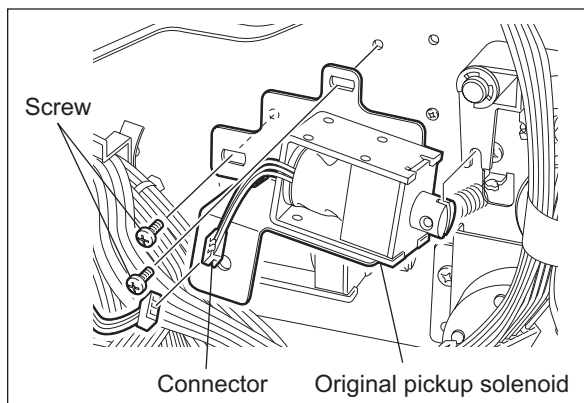

Fig.4-66

- (3) Remove 2 screws and take off the original pickup solenoid from the bracket.

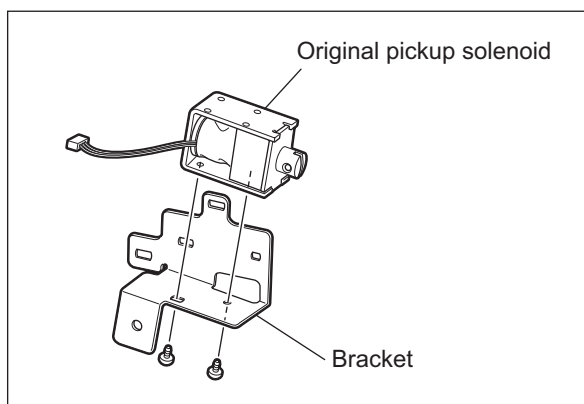

Fig.4-67

Note:

When installing the original pickup solenoid, be sure to align the edge of the original pickup solenoid with the mark-off line on the frame.

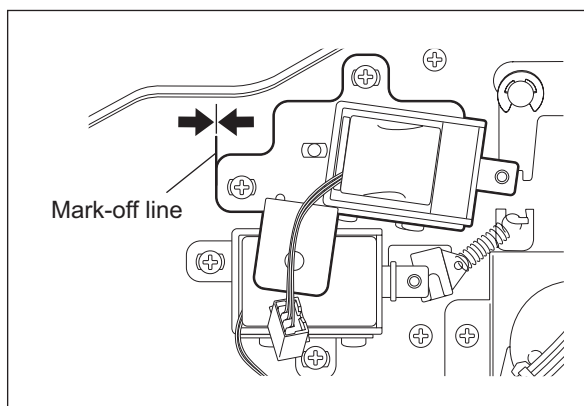

Fig.4-68

[B] Gate solenoid (SOL2)

- (1) Take off the original pickup solenoid.
(P.4-24 "[A] Original pickup solenoid (SOL1)")
- (2) Disconnect one connector. Remove 2 screws and take off the gate solenoid with the bracket.

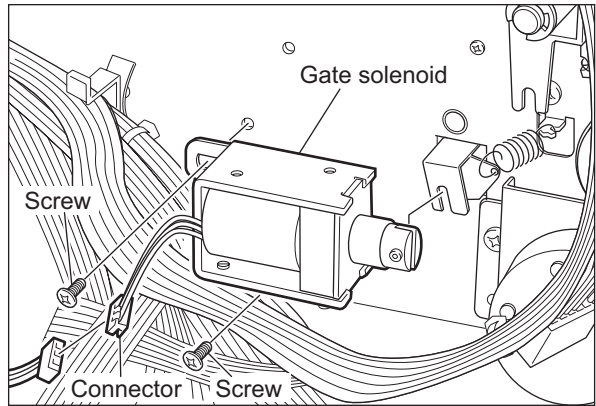

Fig.4-69

- (3) Remove 2 screws and take off the gate solenoid from the bracket.

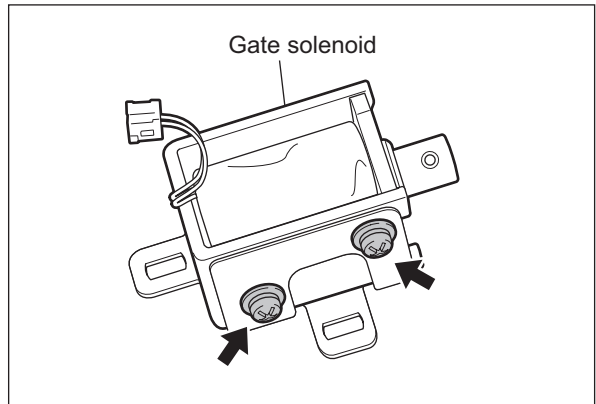

Fig.4-70

Note:

When installing the gate solenoid, be sure to align the edge of the bracket with the mark-off line on the frame.

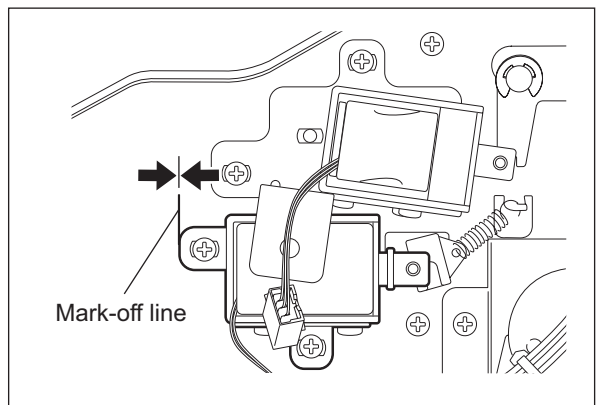



Fig.4-71

4.5 Sensor/switch

[A] Original tray width sensor (S2)

- (1) Take off the original reverse tray.
( P.4-5 "[F] Original reverse tray")
- (2) Remove 2 screws. Release 8 latches and separate the original tray into 2 parts.

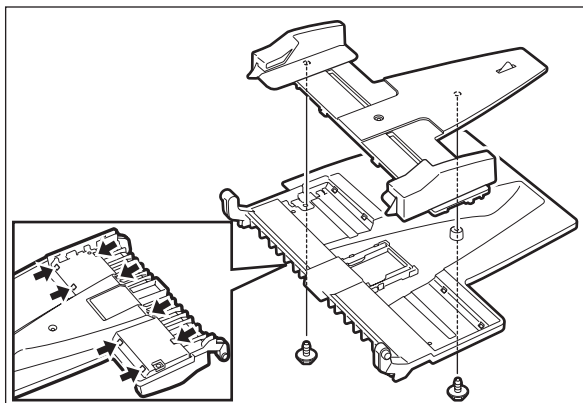

Fig.4-72

- (3) Remove 1 screw and take off the original tray width sensor.

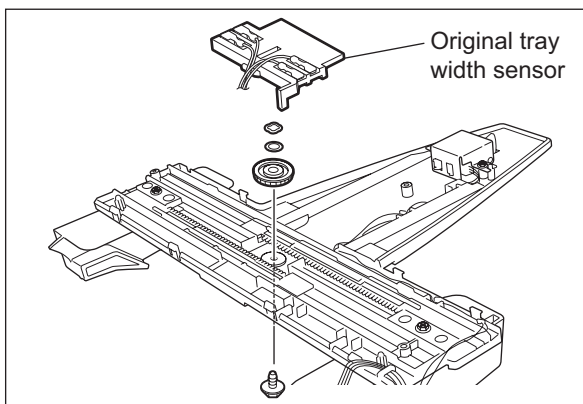



Fig.4-73

[B] Original tray sensor (S1)

- (1) Take off the original reverse tray.
( P.4-5 "[F] Original reverse tray")
- (2) Remove 2 screws. Release 8 latches and separate the original tray into 2 parts.

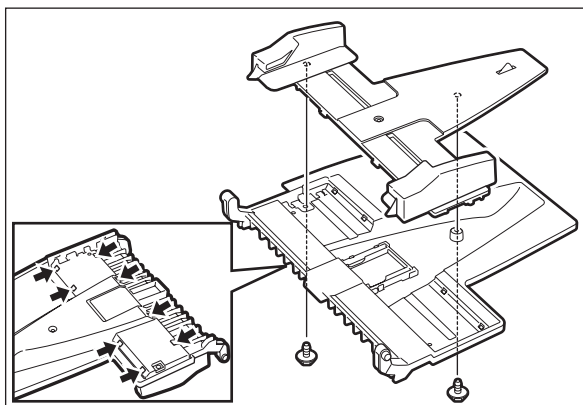

Fig.4-74

- (3) Remove 2 screws and take off the holder.

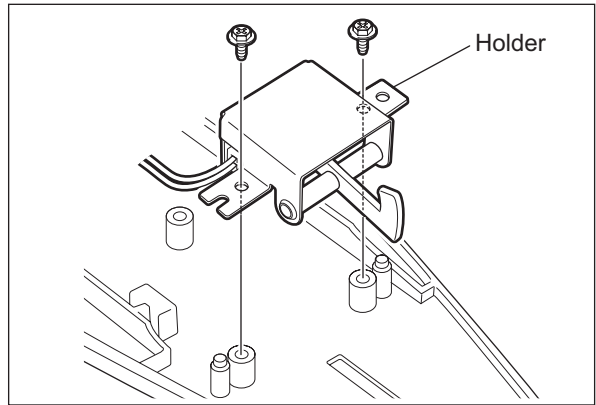

Fig.4-75

- (4) Release 2 latches and take off the original tray sensor.

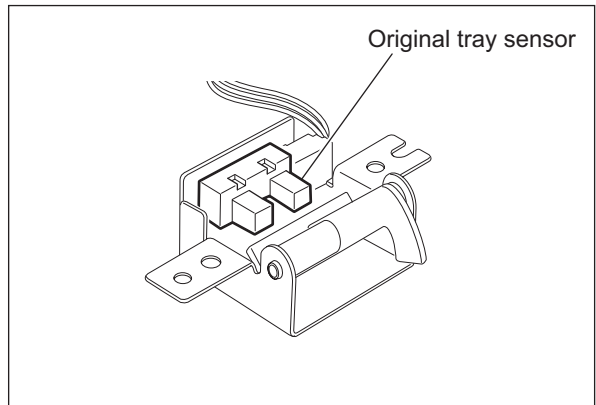

Fig.4-76

[C] Jam access cover sensor (S11)

- (1) Open the jam access cover.
(2) Remove 1 screw and take off the metal plate cover.

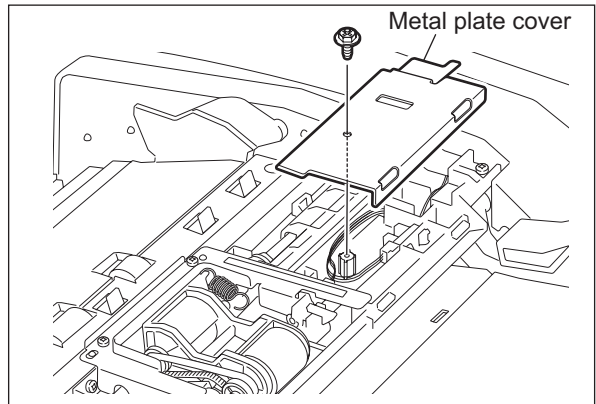

Fig.4-77

- (3) Disconnect 1 connector. Release 2 latches and take off the jam access cover sensor.

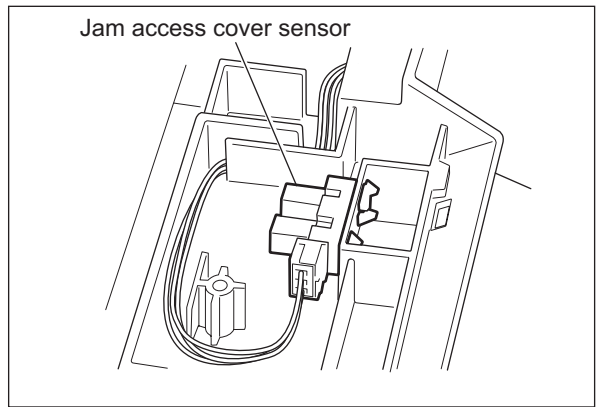

Fig.4-78

[D] Original empty sensor (S3)

- (1) Open the jam access cover.
(2) Remove 1 screw and take off the metal plate cover.

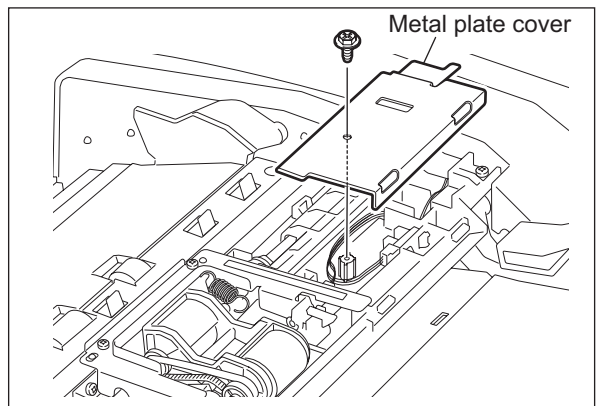

Fig.4-79

- (3) Remove 2 screws and take off the bracket.

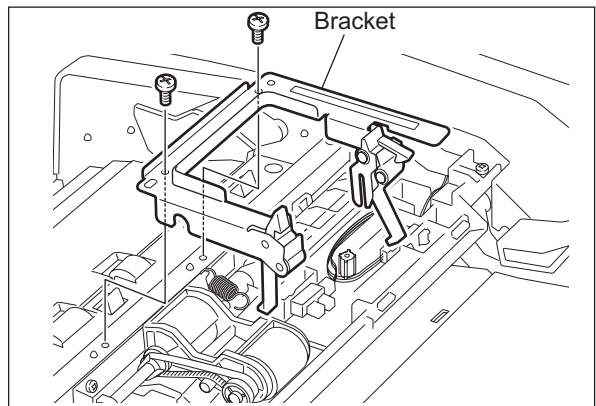

Fig.4-80

- (4) Disconnect 1 connector. Release 2 latches and take off the original empty sensor.

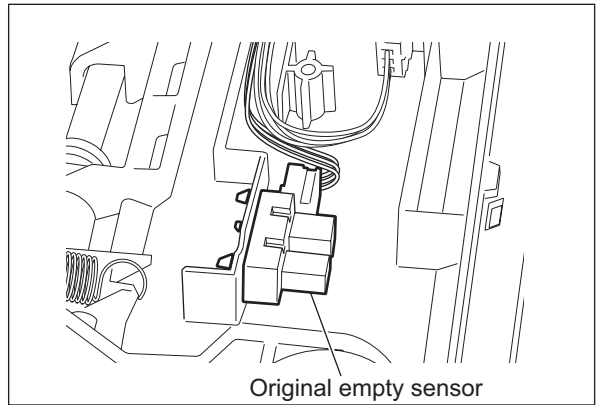

Fig.4-81

[E] Original length detection sensor (S4)

- (1) Take off the feeder lower guide.
(P.4-10 "[E] Feeder lower guide")
- (2) Disconnect 1 connector. Release 2 latches and take off the original length detection sensor.

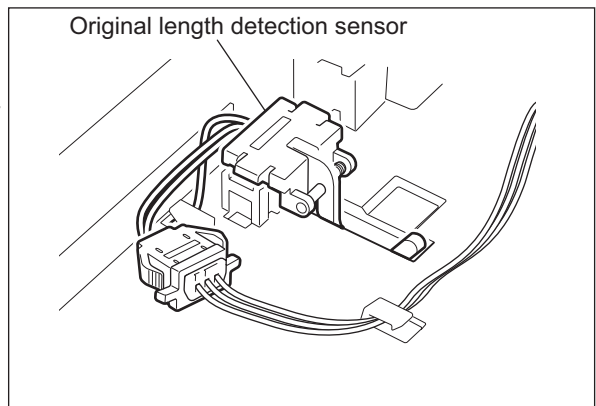

Fig.4-82

[F] Original registration sensor (S5)

- (1) Take off the feeder lower guide.
(P.4-10 "[E] Feeder lower guide")
- (2) Disconnect 1 connector. Release 2 latches and take off the original registration sensor.

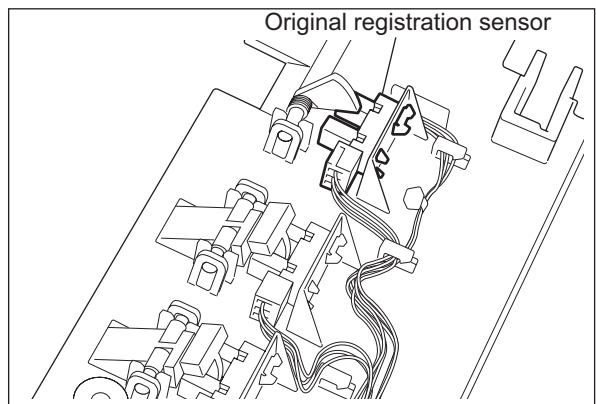



Fig.4-83

[G] Original width detection sensor-1 (S6)

- (1) Take off the feeder lower guide.
( P.4-10 "[E] Feeder lower guide")
- (2) Take off the actuator.
- (3) Disconnect 1 connector. Release 2 latches and take off the original width detection sensor-1.

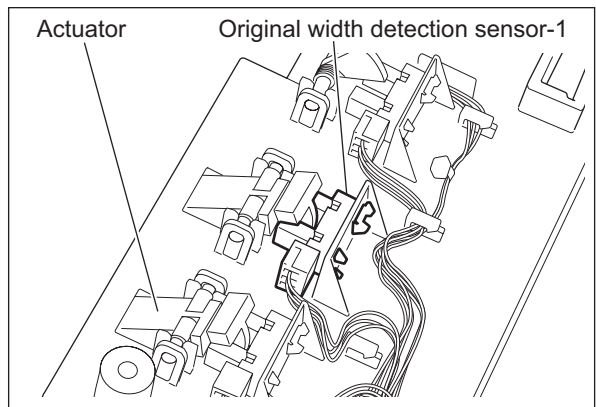



Fig.4-84

[H] Original width detection sensor-2 (S7)

- (1) Take off the feeder lower guide.
( P.4-10 "[E] Feeder lower guide")
- (2) Take off the actuator.
- (3) Disconnect 1 connector. Release 2 latches and take off the Original width detection sensor-2.

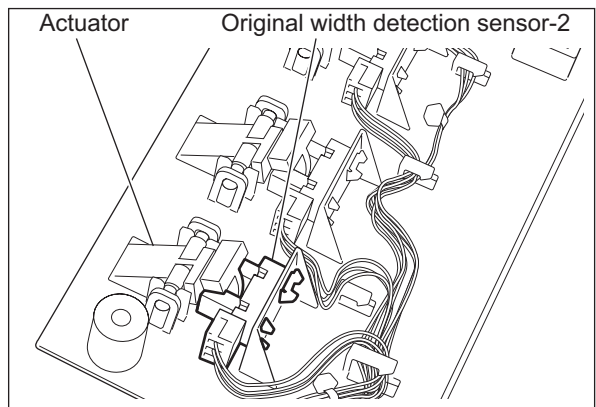



Fig.4-85

[I] Read sensor (S9)

- (1) Take off the pre-reading upper guide.
( P.4-13 "[H] Pre-reading lower guide / pre-reading upper guide")
- (2) Release 2 latches and take off the read sensor from the pre-reading upper guide.

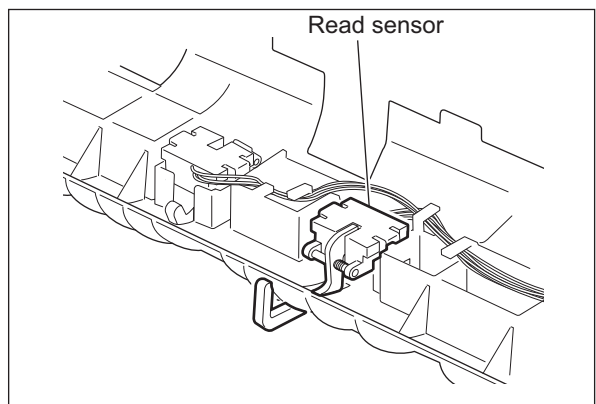



Fig.4-86

[J] Intermediate transport sensor (S8)

- (1) Take off the pre-reading upper guide.
( P.4-13 "[H] Pre-reading lower guide / pre-reading upper guide")
- (2) Release 2 latches and take off the intermediate transport sensor from the pre-reading upper guide.

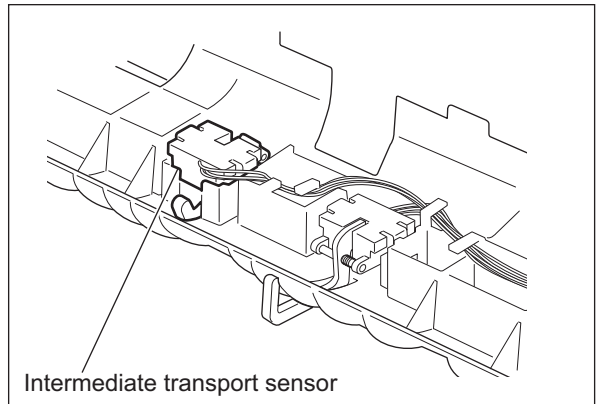



Fig.4-87

[K] Original exit/reverse sensor (S10)

- (1) Take off the pre-reading lower guide.
( P.4-13 "[H] Pre-reading lower guide / pre-reading upper guide")
- (2) Disconnect 1 connector.

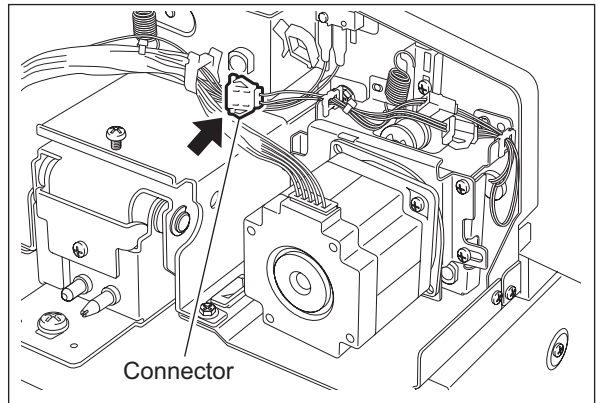

Fig.4-88

- (3) Open the RADF. Remove 2 screws, and then take off 2 holders and platen guide.

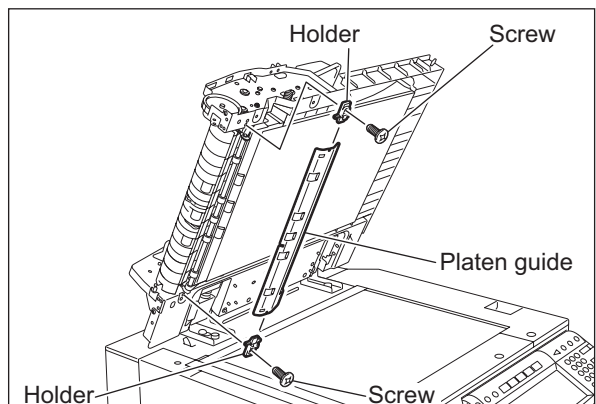

Fig.4-89

- (4) Remove 2 screws. Open the post-reading lower guide and take off the post-reading upper guide.

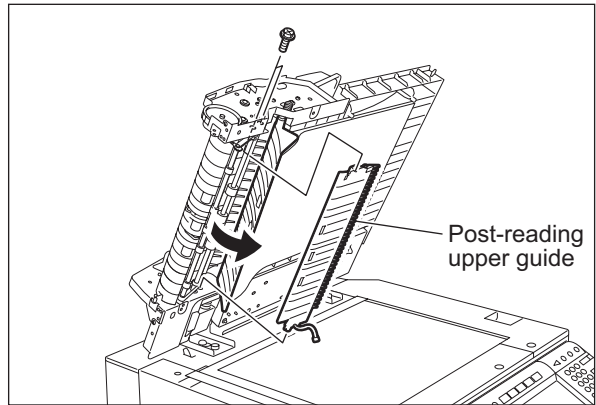

Fig.4-90

- (5) Release 2 latches and take off the Original exit/reverse sensor from the post-reading upper guide.

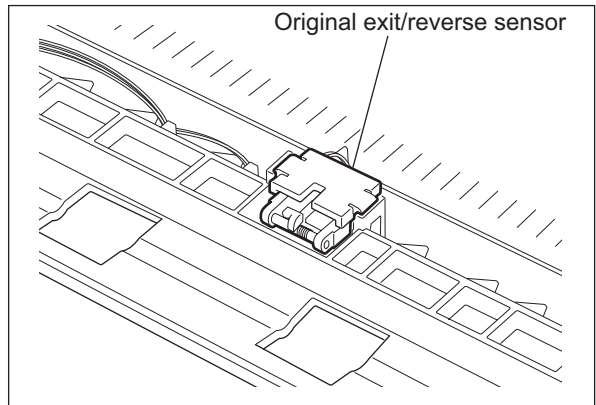

Fig.4-91

[L] RADF opening/closing sensor (S12)

- (1) Take off the rear cover.
(P.4-2 "[B] Rear cover")
- (2) Disconnect 1 connector. Release 2 latches and take off the RADF opening/closing sensor.

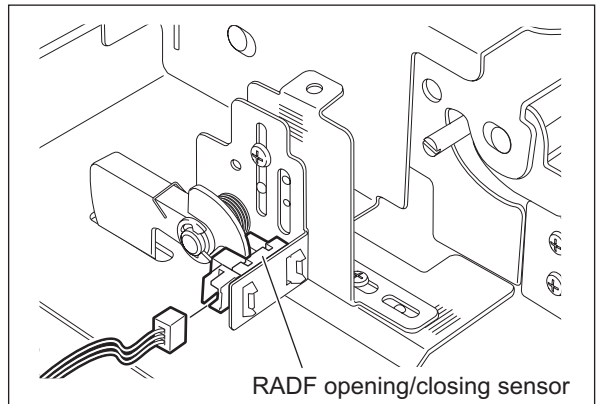



Fig.4-92

[M] Jam access cover opening/closing switch (SW1)

- (1) Take off the bracket of the original feed motor drive section.
( P.4-21 "[E] Original feed motor drive section")
- (2) Disconnect 2 terminals. Remove 1 screw and take off the jam access cover opening/closing switch.

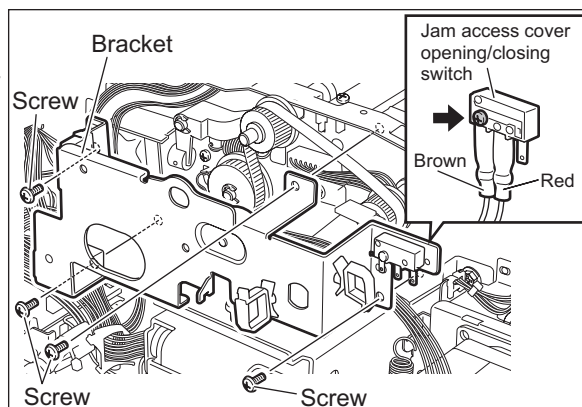



Fig.4-93

4.6 PC Board

[A] RADF control PC board (ADF board)

- (1) Take off the rear cover.
( P.4-2 "[B] Rear cover")
- (2) Disconnect 11 connectors.

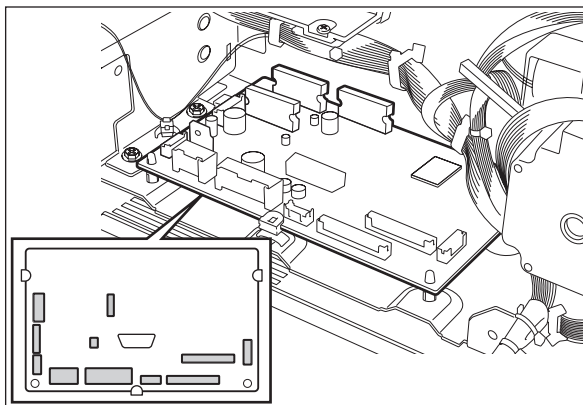

Fig.4-94

- (3) Release 2 lock supports and 3 edge spacer.
Take off the ADF board.

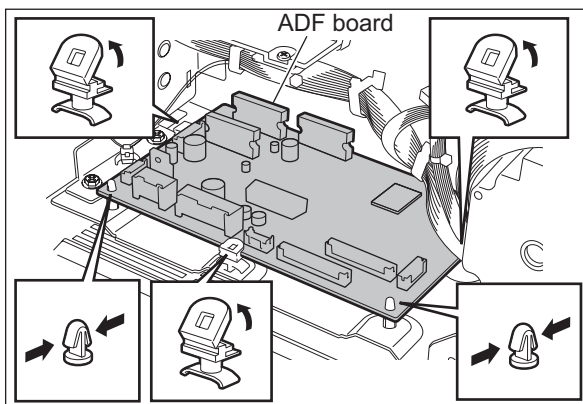

Fig.4-95

4.7 Others

[A] Hinge stopper

- (1) Remove 1 screw and then take off the hinge stopper.

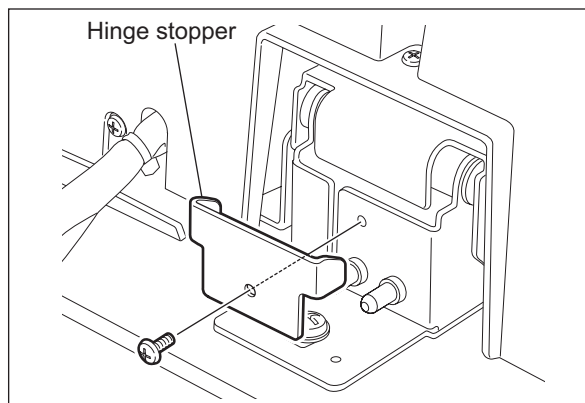

Fig.4-96

Note:

When the hinge stopper is taken off, the opening angle for the RADF becomes approx. 90 degrees. Take off the hinge stopper only when it is needed for installation, maintenance service, etc.

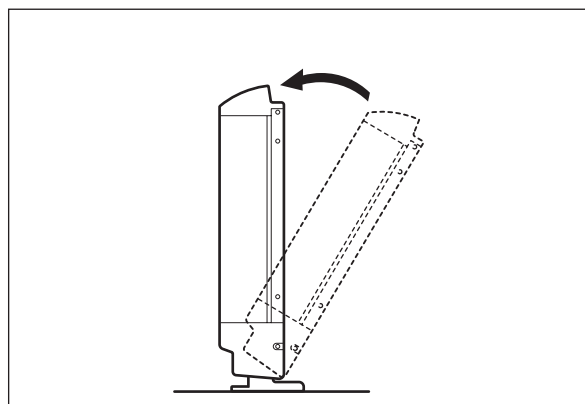

Fig.4-97

5. Adjustment

5.1 Adjustment of Position

Perform this adjustment when the RADF is not installed in the correct position.

Note:

Check if the image adjustment for the equipment is performed properly before this adjustment of the RADF. (See the Service Handbook of the applicable equipment.)

[A] Checking

- (1) Open the RADF and install 2 positioning pins (the positioning pins are installed to the back side of the hinge which is on the left side of the RADF).

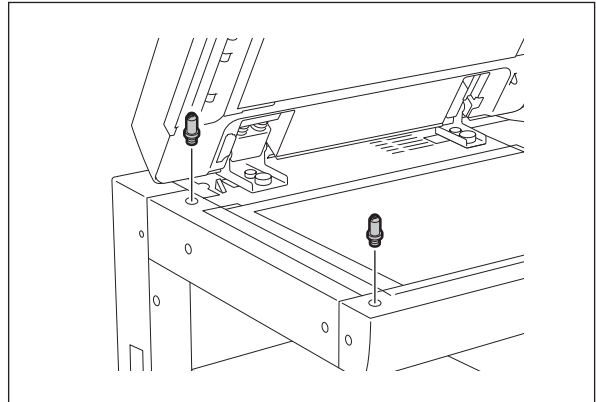

Fig.5-1

- (2) Remove the platen sheet.

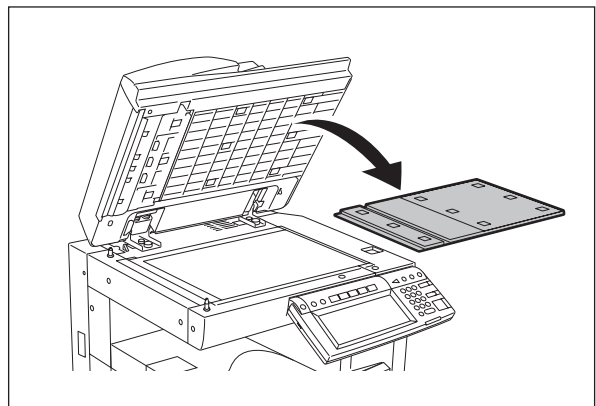

Fig.5-2

- (3) Close the RADF and check if the positioning pins fit the holes on the RADF.

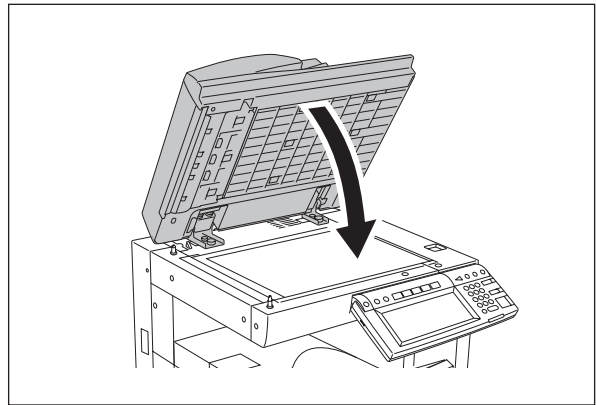

Fig.5-3

[B] Adjustment

If the pins cannot be fitted into the holes, perform the adjustment according to the following procedure.

- (1) Remove the right-hand hinge screw at the rear side.

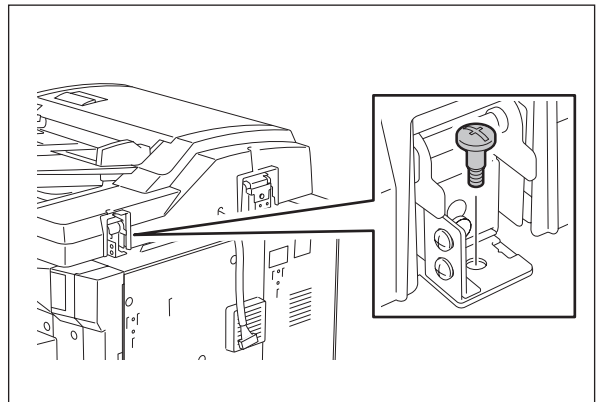

Fig.5-4

- (2) Loosen the left-hand hinge screw at the rear side.

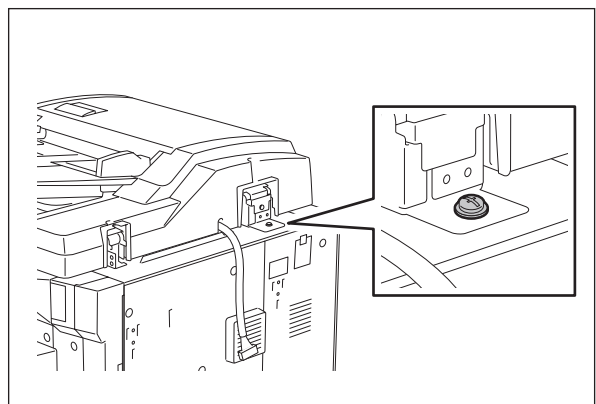

Fig.5-5

- (3) Loosen the hinge screws at the front side.

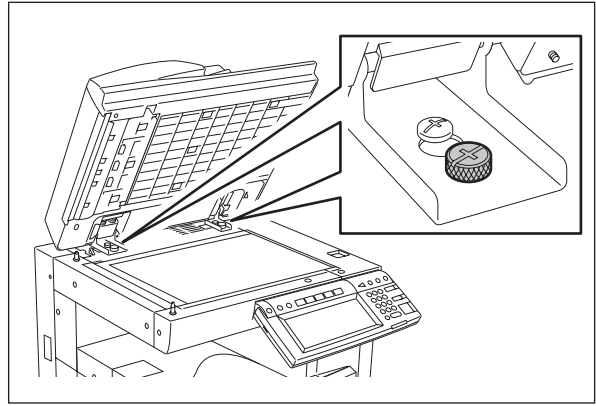

Fig.5-6

- (4) Position the pins with the holes on the RADF by moving it so that the pins fit into the holes when the RADF is closed.

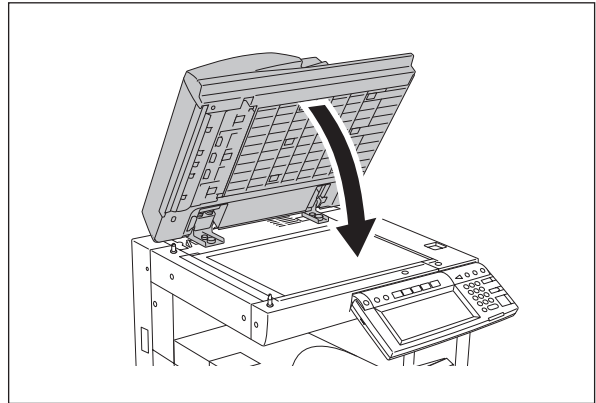

Fig.5-7

- (5) Tighten the left-hand hinge screw at the rear side.

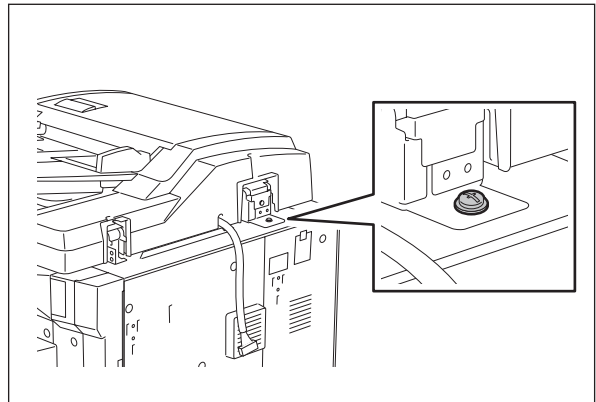

Fig.5-8

- (6) Loosen the hole position adjustment screws on the right hand side.

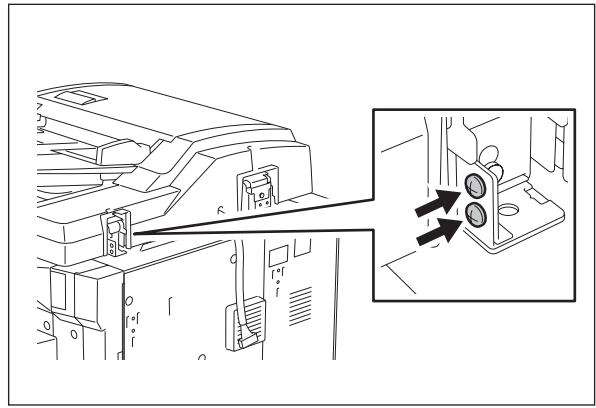

Fig.5-9

- (7) Match the screw hole positions.

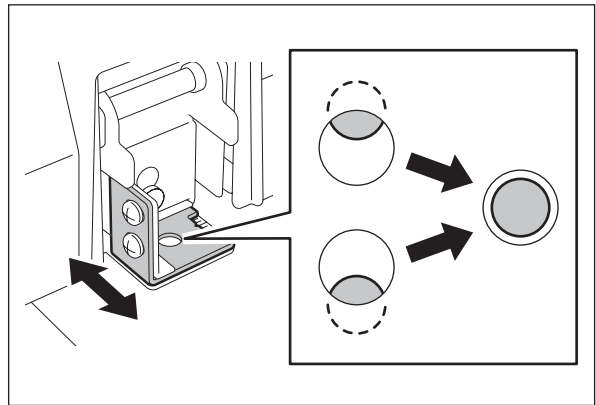

Fig.5-10

- (8) Install the right-hand hinge screw at the rear side.

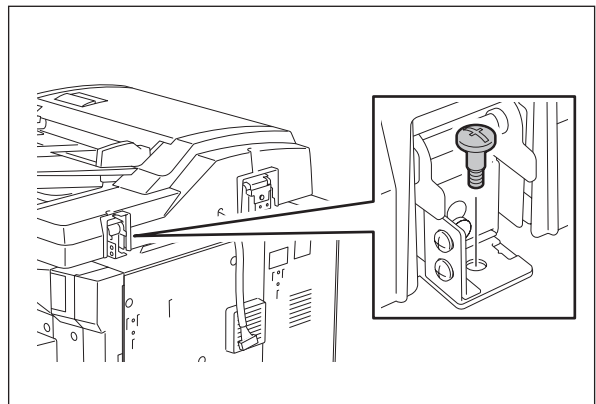

Fig.5-11

(9) Loosen the hinge screws at the front side.

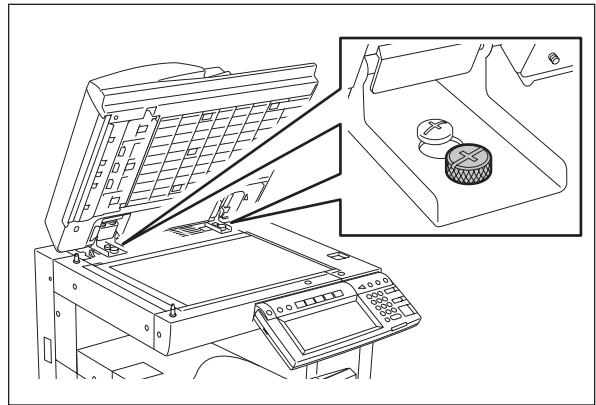

Fig.5-12

(10) Place the platen sheet on the original glass and align it to the top left corner.
Close the RADF gently and open it to check if the platen sheet is attached properly.

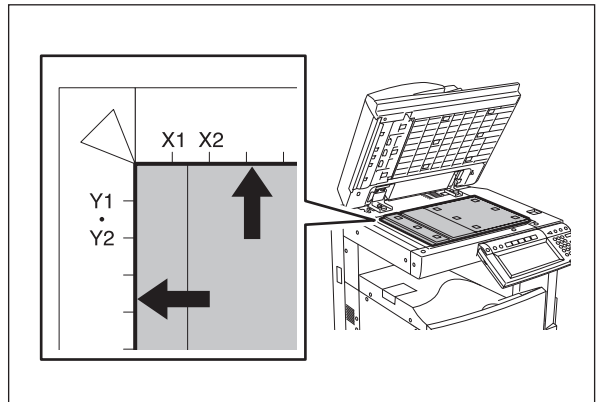

Fig.5-13

5.2 Adjustment of Height

Note:

Check if the image adjustment for the equipment is performed properly before this adjustment of the RADF. (See the Service Handbook of the applicable equipment.)

[A] Checking

- (1) Close the RADF.
- (2) Light the exposure lamp.
 - Turn the power ON while pressing [0] and [3] simultaneously.
 - Key in [267] and then press the [START] button. The exposure lamp is turned ON for a given length of time.
- (3) Visually check the gap between platen guide holder "A" and upper surface of the original glass "B" from the left hand side of the equipment. If the value is not within the tolerance, perform the adjustment according to the following procedure.

[Tolerance of the gap]

Rear side: 0 - 0.5 mm

Front side: 0 mm

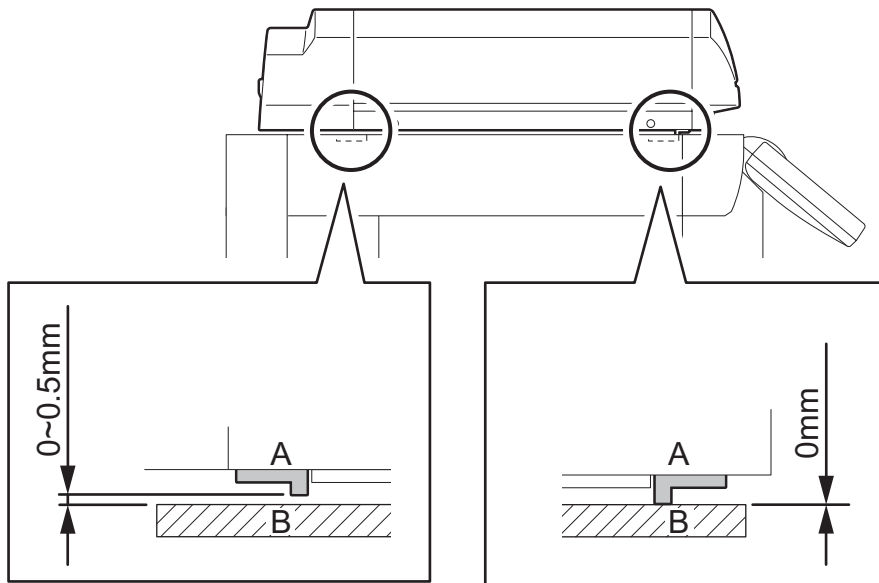

Fig.5-14

[B] Adjustment

- (1) Close the RADF.
- (2) Adjust it by turning the adjustment screws on the hinges.
 - Adjust the height on the rear side by means of the screw on the hinge on the feed side of the RADF.Turn it clockwise Heightened
Turn it counterclockwise Lowered

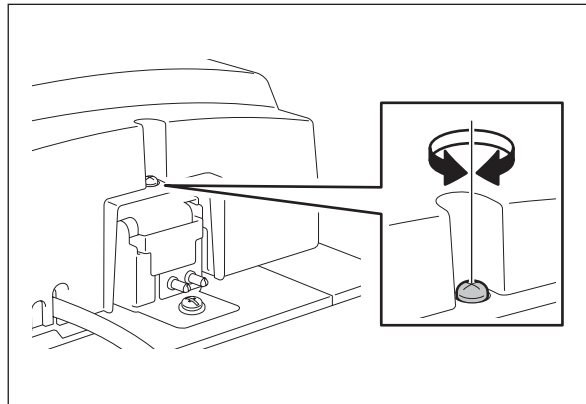

Fig.5-15

- Adjust the gap on the rear side by means of the screw on the hinge on the feed side of the RADF.
- Turn it clockwis Lowered
-
- Turn it counterclockwise Heightened

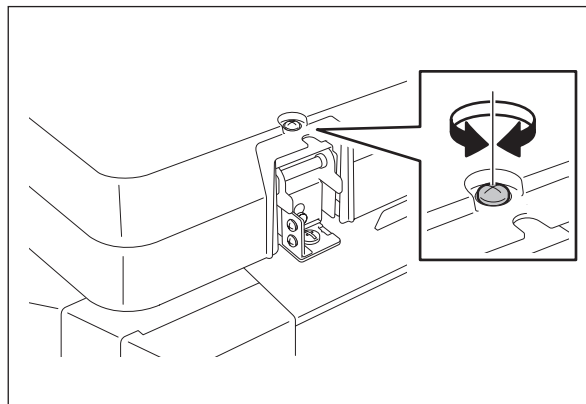

Fig.5-16

5.3 Adjustment of Skew

Note:

Check if the image adjustment for the equipment is performed properly before this adjustment of the RADF. (See the Service Handbook of applicable equipment.) Also, the RADF position and height shall be adjusted properly.

[A] Checking

Check the image using the chart (original) with vertical and horizontal lines in the following procedure.

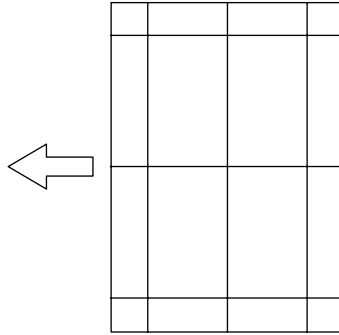

Fig.5-17 Chart (Original)

Simplex copying:

- (1) Place the chart provided as an original with its face up on the original tray of the RADF, select [1 Sided -> 1 Sided] and press the [START] button.
- (2) Superimpose the chart on the copy and check the inclination of the copy image.

Duplex copying:

- (1) Place the chart provided as an original with its face up on the original tray of the RADF, select [2 Sided -> 2 Sided] and press the [START] button.
- (2) Superimpose the chart on the copy and check the inclination of the copy image.

[B] Adjustment
Simplex copying:

- (1) Shift the aligning plate with the scale as the guide shown in the figure below to adjust the skew.

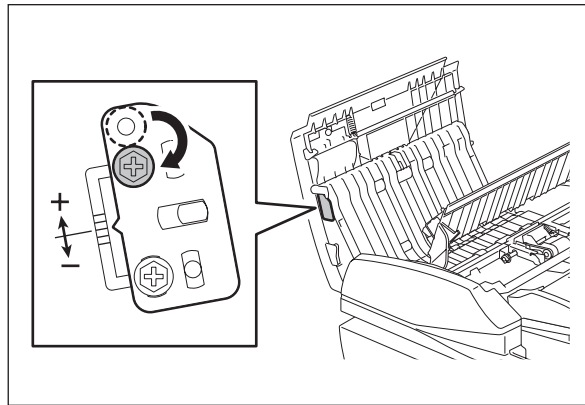

Fig.5-18

- (2) If the image skew is "C" as shown in the figure below, shift the aligning plate in the direction of "+", and if "D", shift it to "-".

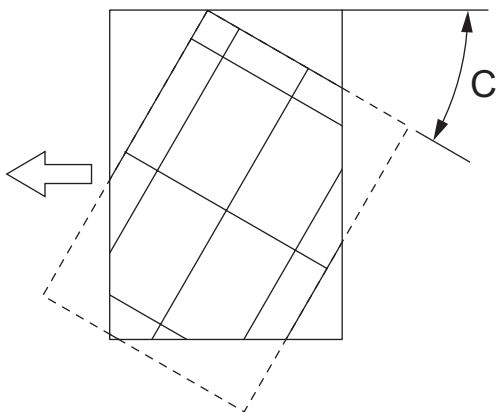

Fig.5-19

Shift the aligning plate in the direction of "+".

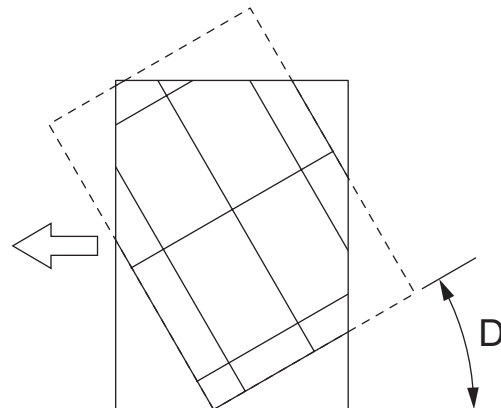

Fig.5-20

Shift the aligning plate in the direction of "-".

Duplex copying:

- (1) Shift the aligning plate with the scale as the guide shown in the figure below to adjust the skew.

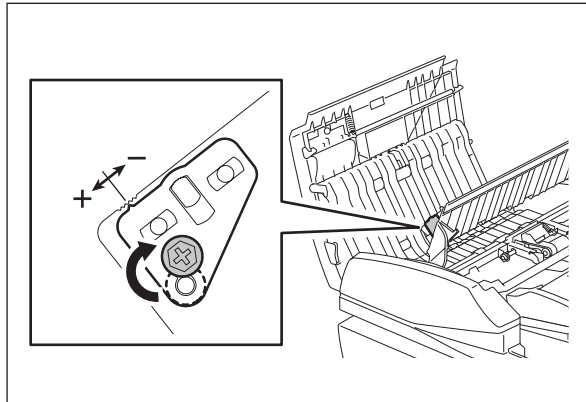

Fig.5-21

- (2) If the image skew is "C" as shown in the figure below, shift the aligning plate in the direction of "-", and if "D", shift it to "+".

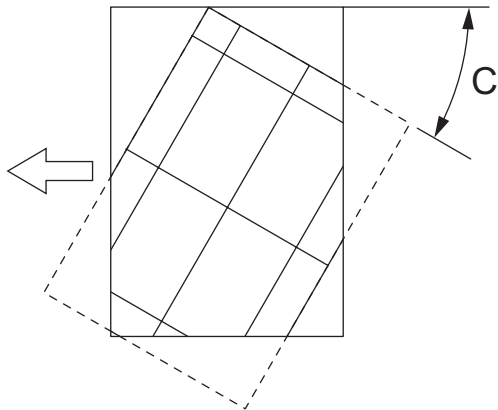

Fig.5-22

Shift the aligning plate in the direction of "-".

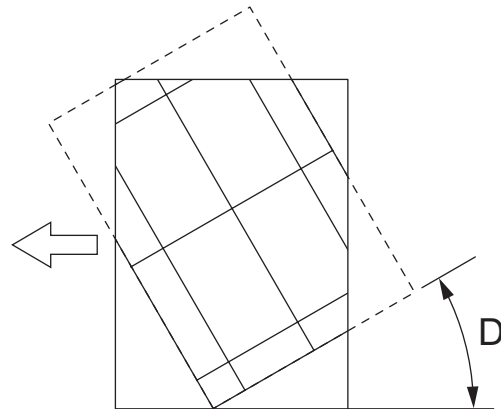

Fig.5-23

Shift the aligning plate in the direction of "+".

5.4 Adjustment of the Leading Edge Position

Note:

Check if the image adjustment for the equipment is performed properly before this adjustment of the RADF. (See the Service Handbook of applicable equipment.) Also, the RADF position and height shall be adjusted properly.

[A] Checking

Check the image using the chart (original) with vertical and horizontal lines in the following procedure.

Simplex copying:

- (1) Place the chart provided as an original with its face up on the original tray of the RADF, select [1 Sided -> 1 Sided] and press the [START] button.
- (2) Superimpose the chart on the copy and check the leading edge E of the chart and F of the copy.

Duplex copying:

- (1) Place the chart provided as an original with its face up on the original tray of the RADF, select [2 Sided -> 2 Sided] and press the [START] button.
- (2) Superimpose the chart on the copy and check the leading edge E of the chart and F of the copy.

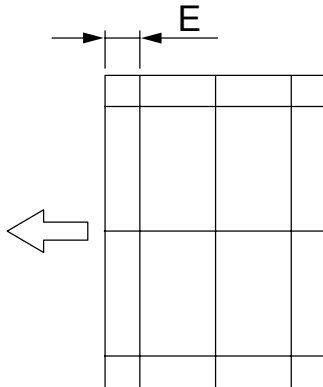

Fig.5-24 Chart (Original)

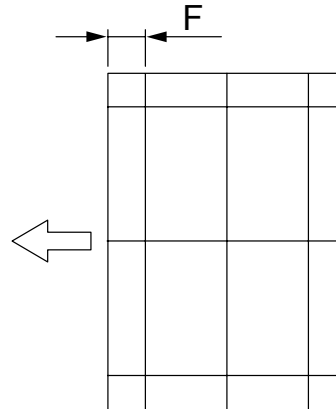

Fig.5-25 Copy

[B] Adjustment

Simplex copying:

- (1) Turn the power ON while pressing [0] and [5] simultaneously, key in [365] and then press the [START] button.
- (2) Enter the value.
 - If the leading edge (F) margin of the copy image is larger than the (E) margin of the chart, enter a value smaller than the current one.

Note:

Changing one value shifts the copy image by 0.1 mm.

- If the leading edge (F) margin of the copy image is smaller than the (E) margin of the chart, enter a value larger than the current one.

Note:

Changing one value shifts the copy image by 0.1 mm.

- (3) Press the [ENTER] button.

Duplex copying:

- (1) Turn the power ON while pressing [0] and [5] simultaneously, key in [366] and then press the [START] button.
- (2) Enter the value.
 - If the leading edge (F) margin of the copy image is larger than the (E) margin of the chart, enter a value smaller than the current one.

Note:

Changing one value shifts the copy image by 0.1 mm.

- If the leading edge (F) margin of the copy image is smaller than the (E) margin of the chart, enter a value larger than the current one.

Note:

Changing one value shifts the copy image by 0.1 mm.

- (3) Press the [ENTER] button.

5.5 Adjustment of Horizontal Position

Note:

Check if the image adjustment for the equipment is performed properly before this adjustment of the RADF. (See the Service Handbook of applicable equipment.) Also, the RADF position and height shall be adjusted properly.

[A] Checking

Check the image using the chart (original) with a center line in the following procedure.

- (1) Place the chart provided as an original with its face up on the original tray of the RADF.
- (2) Press the [START] button.
- (3) Fold the copy in half and check if the center line is misaligned.

[B] Adjustment

- (1) Turn the power ON while pressing [0] and [5] simultaneously.
- (2) Key in [358] and then press the [START] button.
 - If the center line of the copy image is shifted to the front side of the equipment, enter a value larger than the current one.

Note:

Changing one value shifts the copy image by 0.042 mm.

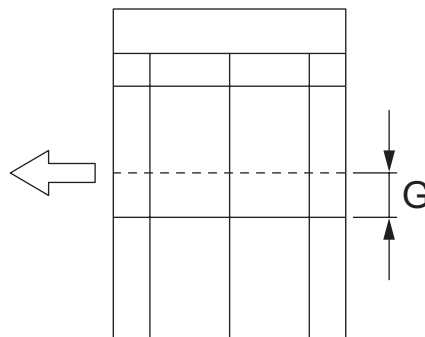

Fig.5-26

- If the center line of the copy image is shifted to the rear side of the equipment, enter a value smaller than the current one.

Note:

Changing one value shifts the copy image by 0.042 mm.

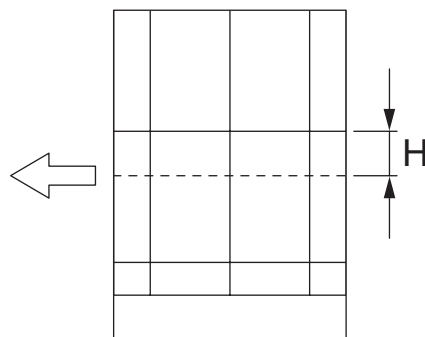

Fig.5-27

- (3) Press the [ENTER] button.

5.6 Adjustment of Copy Ratio

Note:

Check if the image adjustment for the equipment is performed properly before this adjustment of the RADF. (See the Service Handbook of applicable equipment.) Also, the RADF position and height shall be adjusted properly.

[A] Checking

Check the image using the chart (original) with vertical and horizontal lines in the following procedure.

- (1) Place the chart provided as an original with its face up on the original tray of the RADF.
- (2) Press the [START] button.
- (3) Superimpose the chart on the copy and check the image dimension "l".

[B] Adjustment

- (1) Turn the power ON while pressing [0] and [5] simultaneously.
- (2) Key in [357] and then press the [START] button.
 - If the copy image dimension "l" is larger than the chart dimension, enter a value smaller than the current one.
 - If the copy image dimension "l" is smaller than the chart dimension, enter a value larger than the current one.

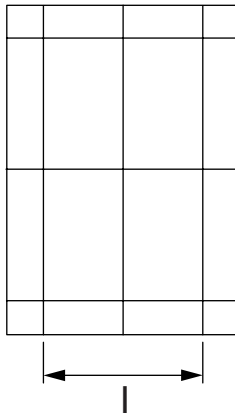

Fig.5-28

- (3) Press the [ENTER] button.

5.7 Adjustment of RADF Opening/Closing Sensor

Adjust the bracket position so that the sensor is turned ON when the height "A" becomes 100 mm or less (within the empty weight falling limit).

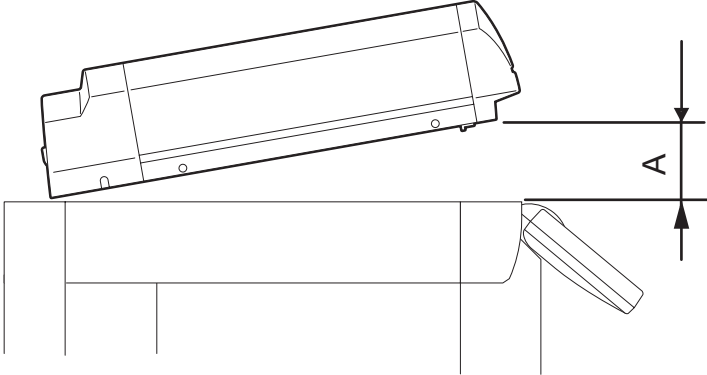

Fig.5-29

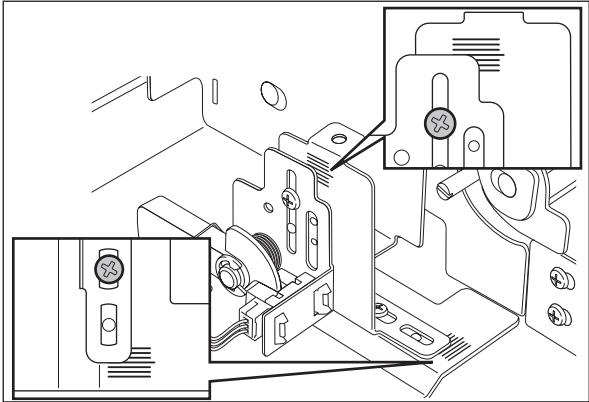

Fig.5-30

6. Troubleshooting

6.1 Troubleshooting for Mechanical Errors

- 1) Multiple originals are transported simultaneously
Original abnormally curled or folded?
↓ YES→ Flatten the original and set it again
NO
Separation roller is dirty?
↓ YES→ Clean the roller with alcohol
NO
Replace the separation rollers with new ones

- 2) Original is not transported to registration roller
Original thicker than specified?
↓ YES→ Use originals with permissible thickness.
↓ Place thick originals manually on the platen cover to make a copy
NO
Pickup roller and feed roller are dirty?
↓ YES→ Clean the rollers with alcohol
NO
Transport power of pickup roller and feed roller is weak?
↓ YES
Replace the rollers with new ones

- 3) Leading edge of original is skewed
Front and rear protrusions at bottom of RADF are out of contact with glass?
↓ YES→ Adjust the height of the left hinge
NO
Transport rollers are dirty?
↓ YES→ Clean the rollers with alcohol
NO
Is the right hinge out of place?
↓ YES
Make a copy and adjust the position of the hinge

- 4) Edges of original and copied image are not aligned
Width between slides too wide compared to that of original?
↓ YES→ Move the slides so that they contact the edges of the original
NO
Check the scanner adjustment

- 5) Black streaks appear on copied image
ADF original glass is dirty?
↓ YES→ Clean the glass with a dry/squeezed cloth
NO
Check the scanner unit

6.2 Troubleshooting for Electrical Errors

- 1) RADF does not work (except in the case of a paper jam or when the cover is open)
Interface harness connected properly?
↓ NO→ Connect the harness properly or replace it
YES
DC+5V supplied to CN70-2, 3pin?
↓ NO→ Connect the harness properly or replace it
YES
DC+24V supplied to CN70-6, 7pin?
↓ NO→ Connect the harness properly or replace it
YES
DC+24V supplied to CN72-4pin?
↓ NO→ Check or replace the jam access cover switch
YES
Empty sensor is ON when there is paper?
↓ NO→ Check or replace the empty sensor
YES
Check or replace the RADF board

- 2) Abnormality of motor
Power supplied and drives signals to connector of motor?
↓ NO→ Check or replace motor
YES
There is no mechanical overloading at the motor and the drive system is correct? (Belt tension etc.)
↓ NO→ Check or replace motor harness
YES
Check or replace the RADF board

- 3) Communication error
Interface cable normal?
↓ NO→ Replace the interface cable
YES
Check or replace the RADF board and check the equipment

- 4) Size detection error
Original tray sensor is ON when there is paper?
↓ NO→ Replace the sensor or harness
YES
Registration roller does not catch the original?
↓ YES→ Clean the roller with alcohol or replace
NO
Original width detection sensor-1 is ON when there is paper?
↓ NO→ Replace the sensor or harness
YES
Original width detection sensor-2 is ON when there is paper?
↓ NO→ Replace the sensor or harness
YES
Check or replace the RADF board

5) Abnormality of fan motor

Is there a foreign matter in the fan motor?

↓ YES→ Remove the extraneous material

NO

Fan harness connected properly?

↓ NO→ Connect the fan harness properly or replace it

YES

Power supplied at CN84-1pin when FAN is ON?

↓ YES→ Replace the fan motor

NO

Check or replace the RADF board

7. MAINTENANCE AND REWRITING ROM

7.1 Periodic Maintenance

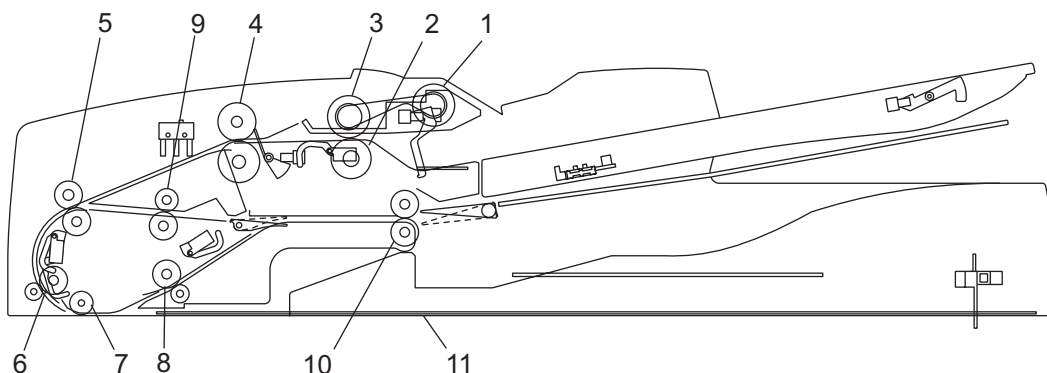

Fig.7-1

Symbols used in the checklist

Cleaning	Lubrication/Coating	Replacement	Operation check
A: Clean with alcohol B: Clean with soft pad, cloth or vacuum cleaner	L: Launa 40 SI: Silicon oil W: White grease (Molykote X5-6020) AV:Alvania No.2	The number of sheets consumed before replacement (Value x 1,000). R: Replace if deformed or damaged	O: After cleaning or replacement, confirm there is no problem

Preventive Maintenance Checklist

Note:

Page-Item (P-I) is described in the column of the Parts list.

Item to check	Cleaning (30K)	Lubrication/Coating	Replacement (x1,000)	Operation check	Parts list (P-I)	Remarks
1 Pickup roller	A		120			
2 Separation roller	A		120			
3 Feed roller	A		120			
4 Registration roller	A					
5 Intermediate transfer roller	A					
6 Front read roller	A					
7 Platen roller	A					
8 Rear read roller	A					
9 Reverse registration roller	A					
10 Exit/reverse roller	A					
11 Platen sheet	B or A					

7.2 Rewriting ROM (Firmware Updating)

It is feasible to update the firmware automatically by connecting the download jig to the PC board and turning the power of the equipment ON. The download jig K-PWA-DLM-320 is used.

< Procedure >

- (1) Turning OFF the power of the equipment and take off the RADF rear cover.
 - (2) Connect the download jig with the connector (CN81) on the PC board.
 - (3) While pressing [0] and [8] simultaneously, turn ON the power. (rewriting data starts)
 - (4) During the data is rewritten, the LED on the download jig lights. When the data rewriting is completed, the LED blinks slowly (at an interval of 0.8 sec.). If the LED blinks fast (at an interval of 0.1 sec.), the rewriting has been failed.
 - (5) Turn OFF the power of the equipment and remove the download jig.
 - (6) Install the RADF rear cover.
- * If rewriting data is failed, turn OFF the power and repeat the procedure.

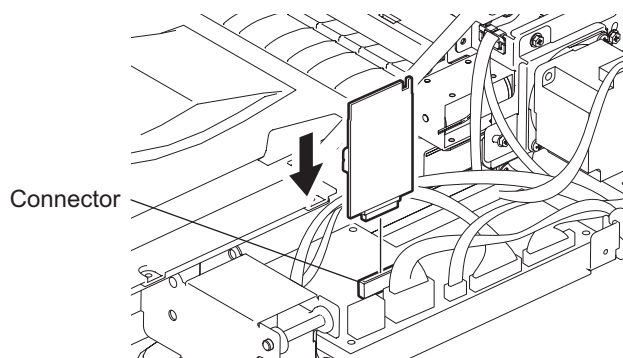

Fig.7-2

8. CIRCUIT DIAGRAM / HARNESS DIAGRAM

8.1 Assembly of PC Board

- Component side

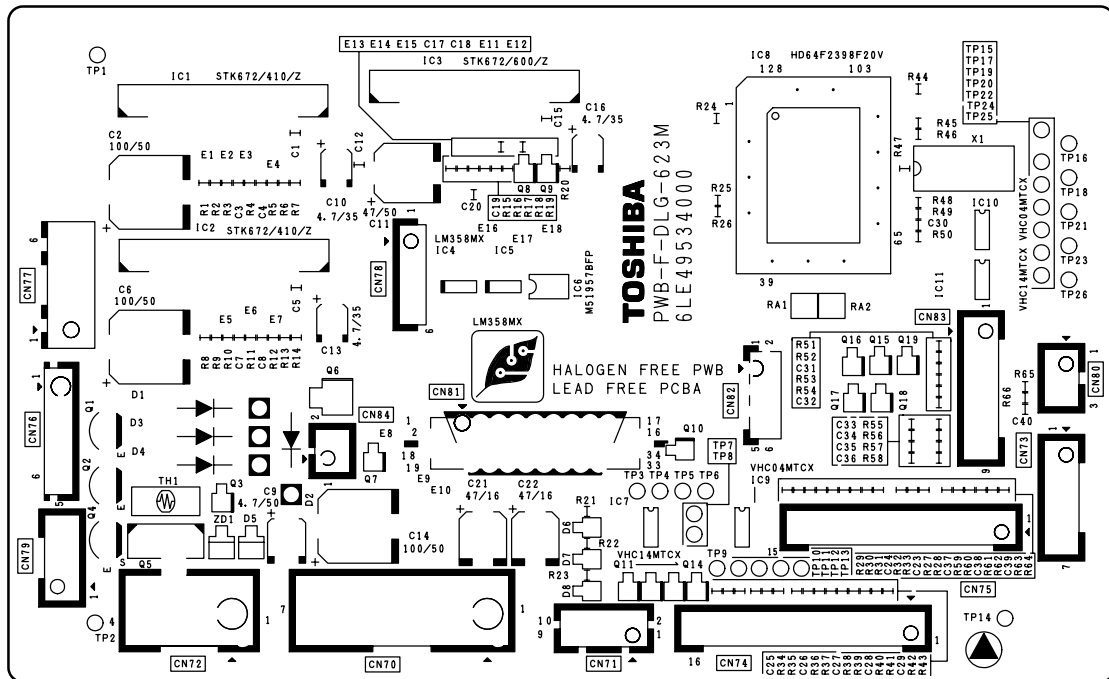

Fig.8-1

- Soldered side

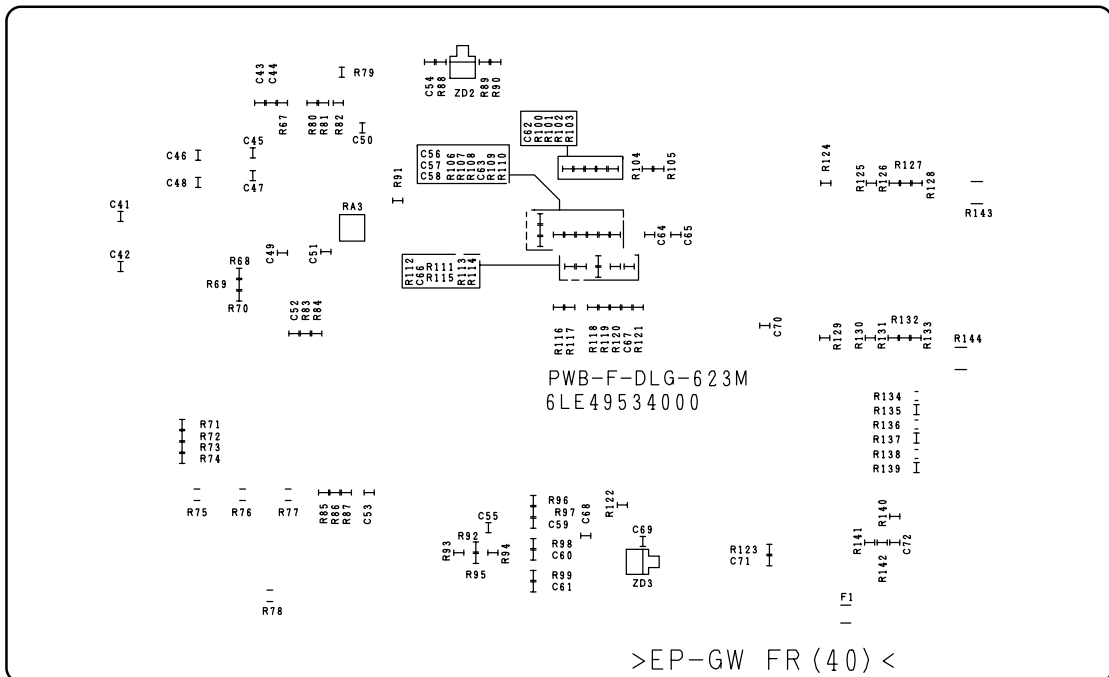
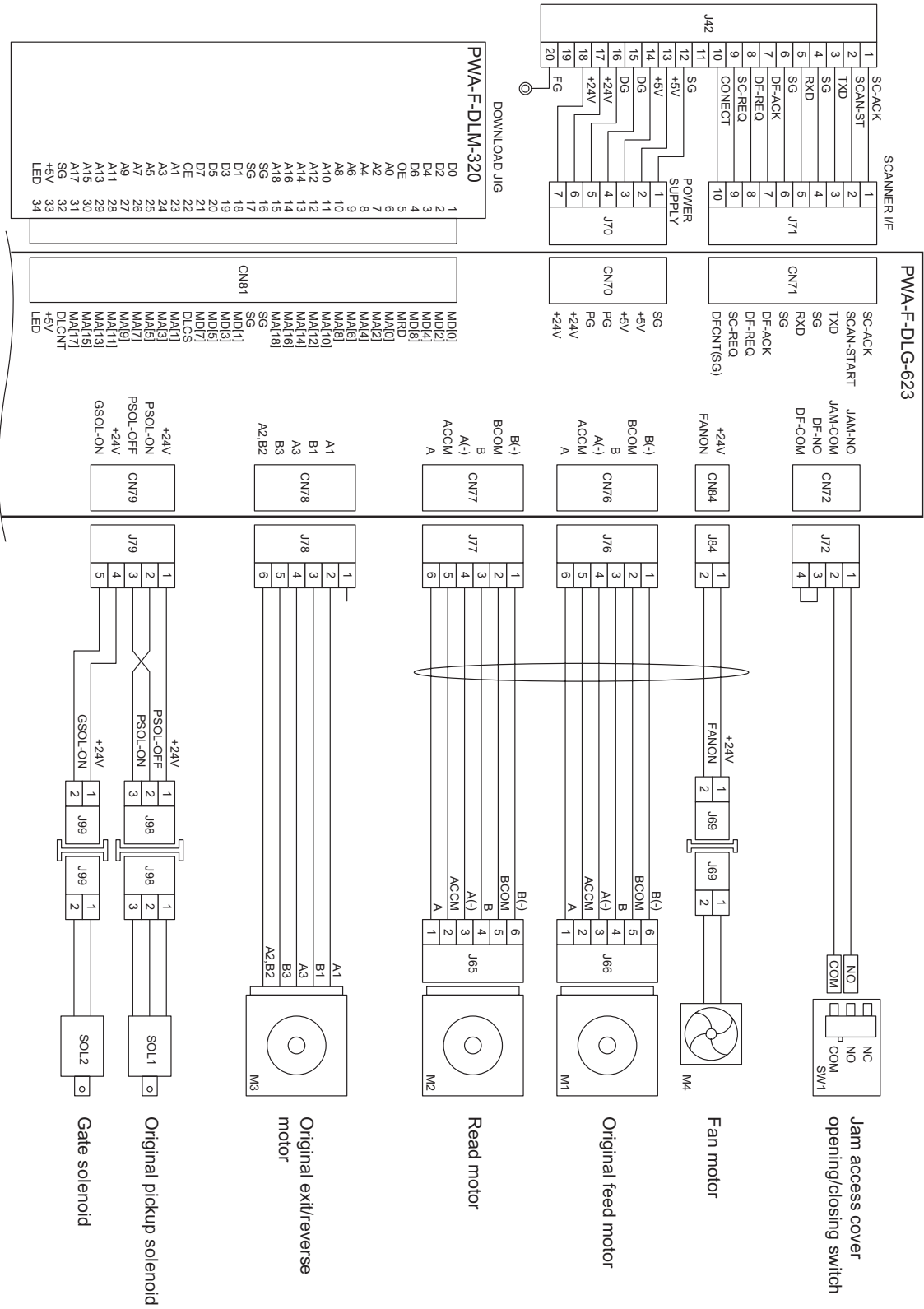
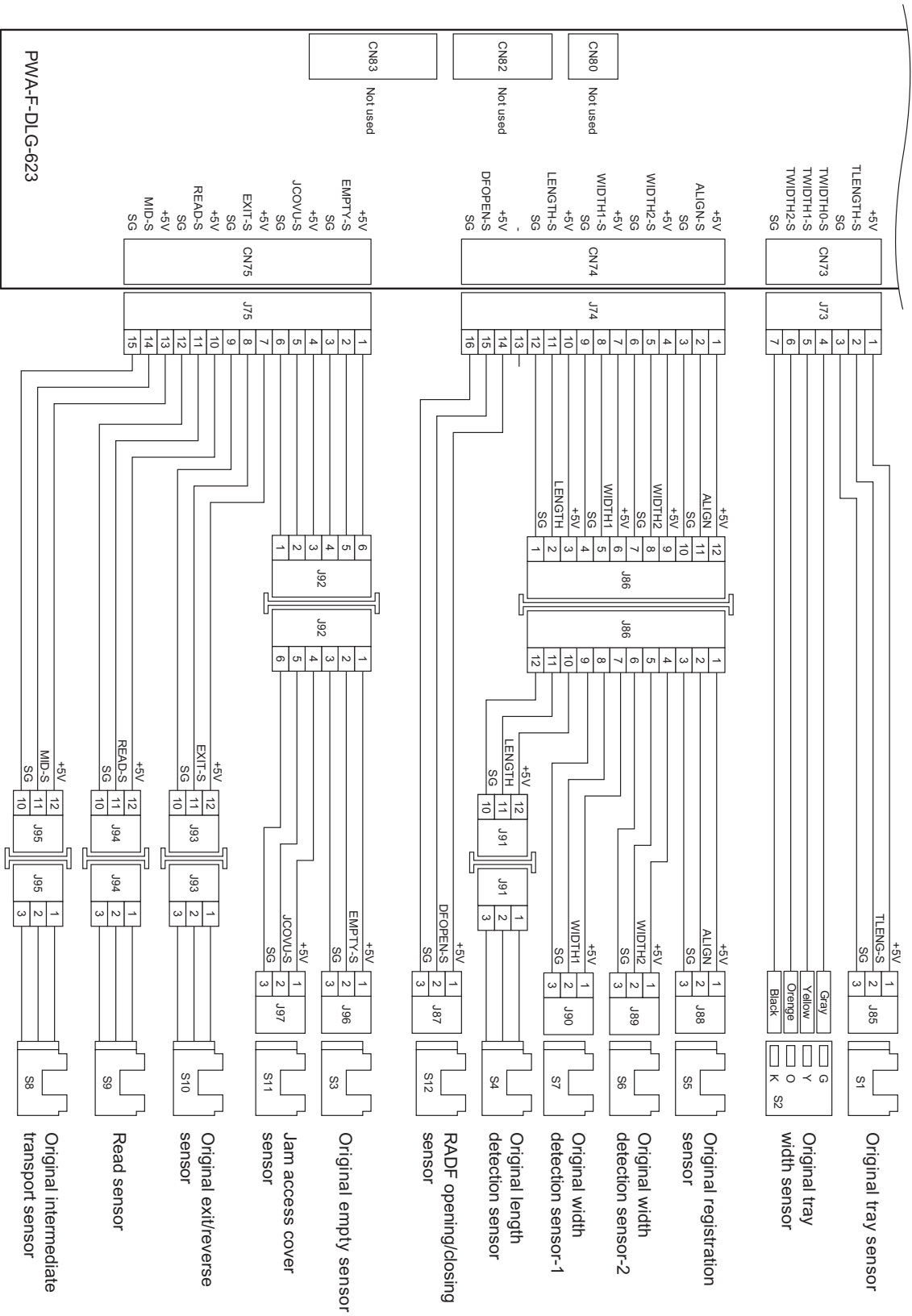

Fig.8-2

8.2 Circuit Diagram





PWA-F-DLG-623

8.3 Control PC Board Circuit

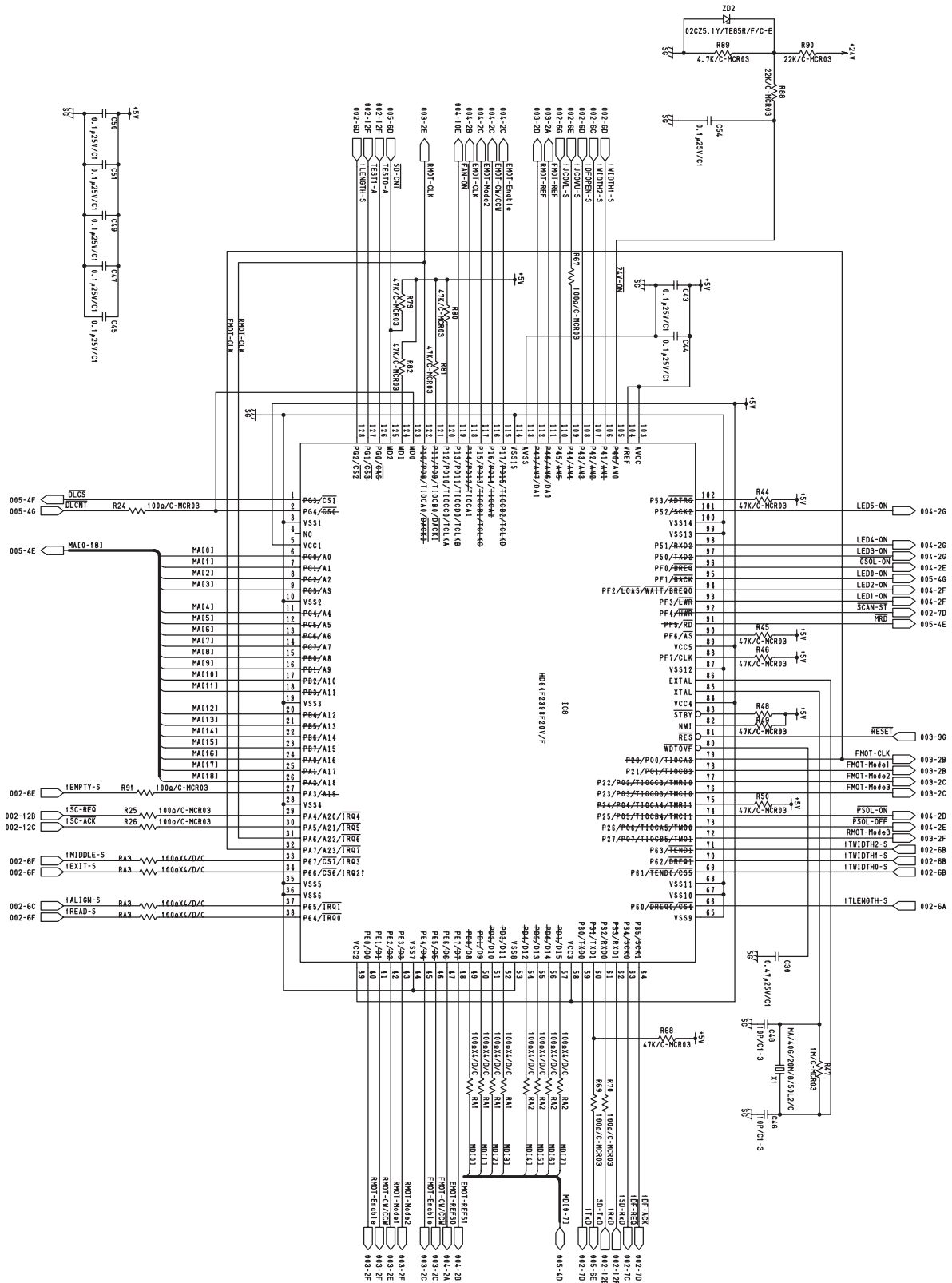

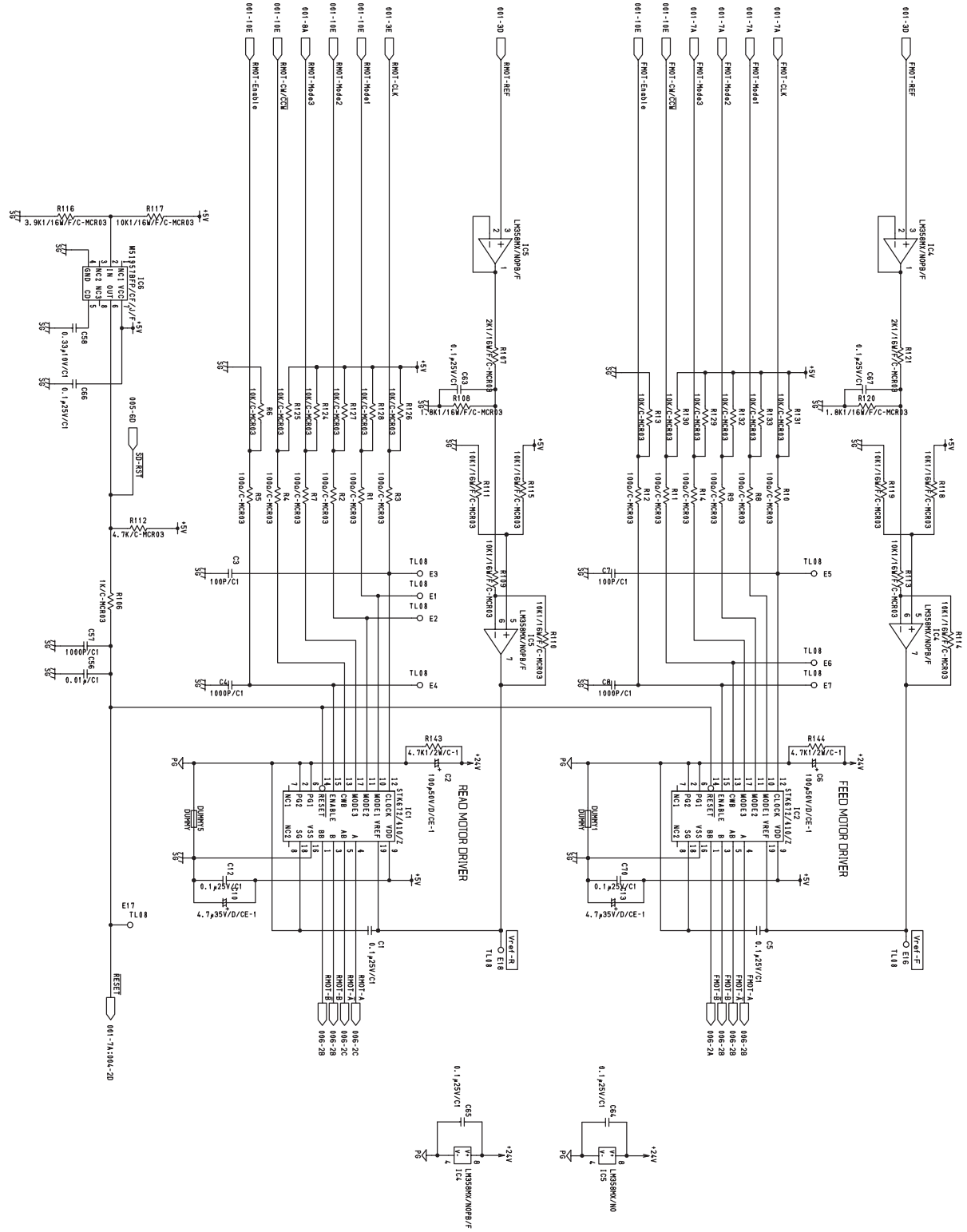

MR-3018 CIRCUIT DIAGRAM / HARNESS DIAGRAM

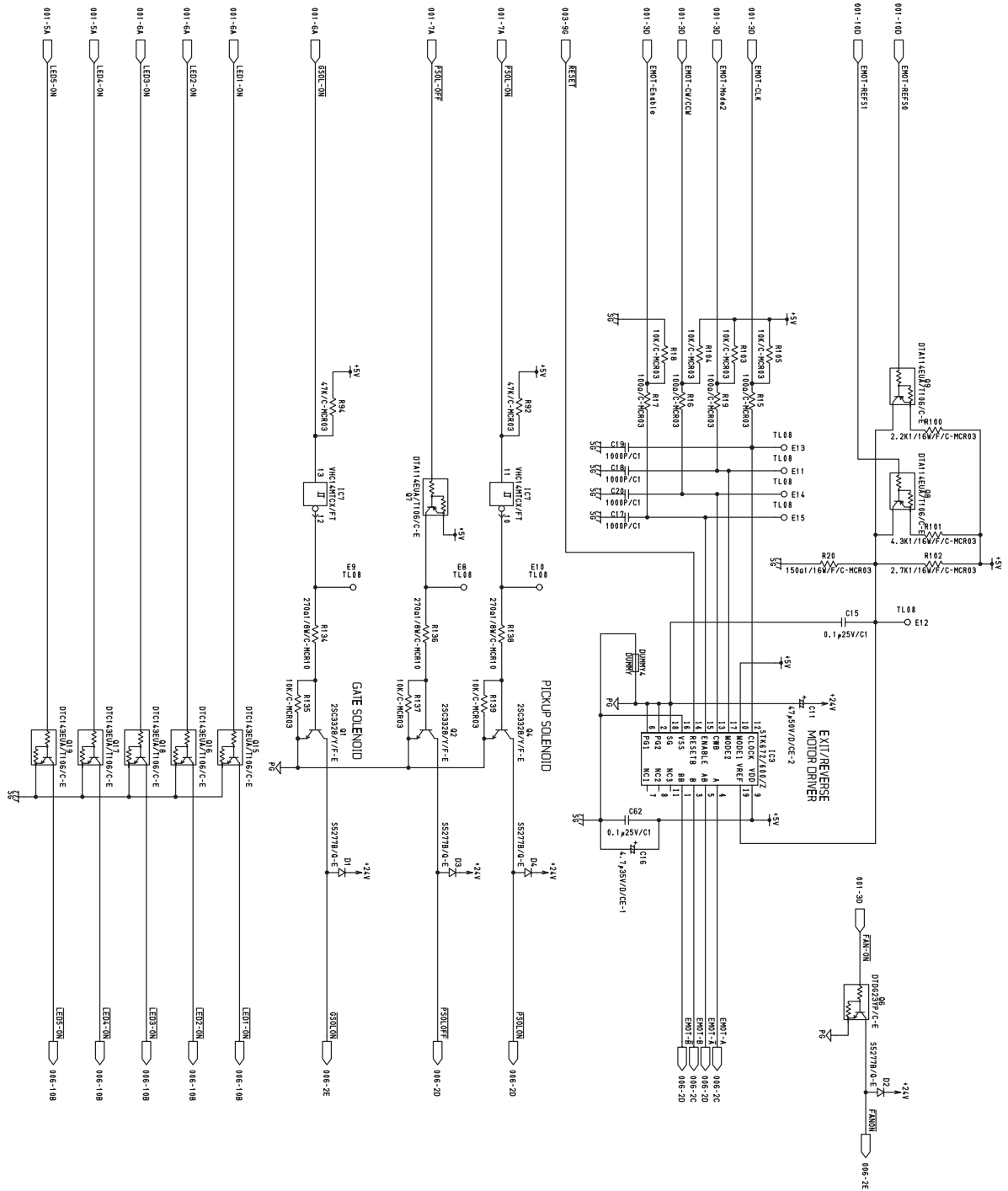

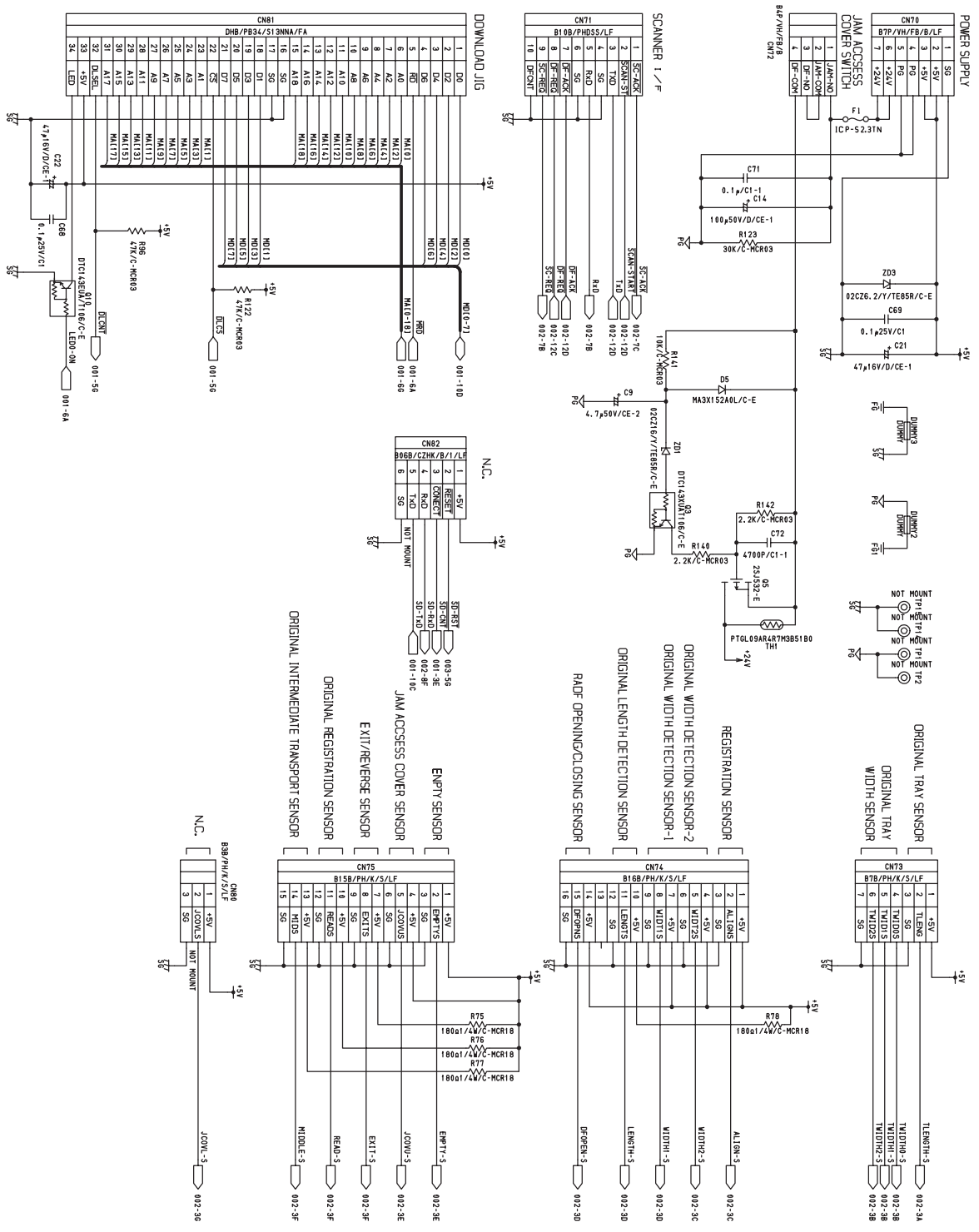

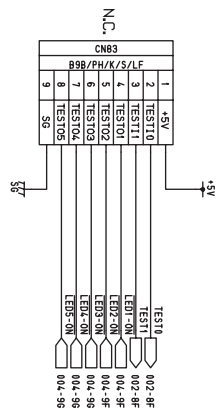
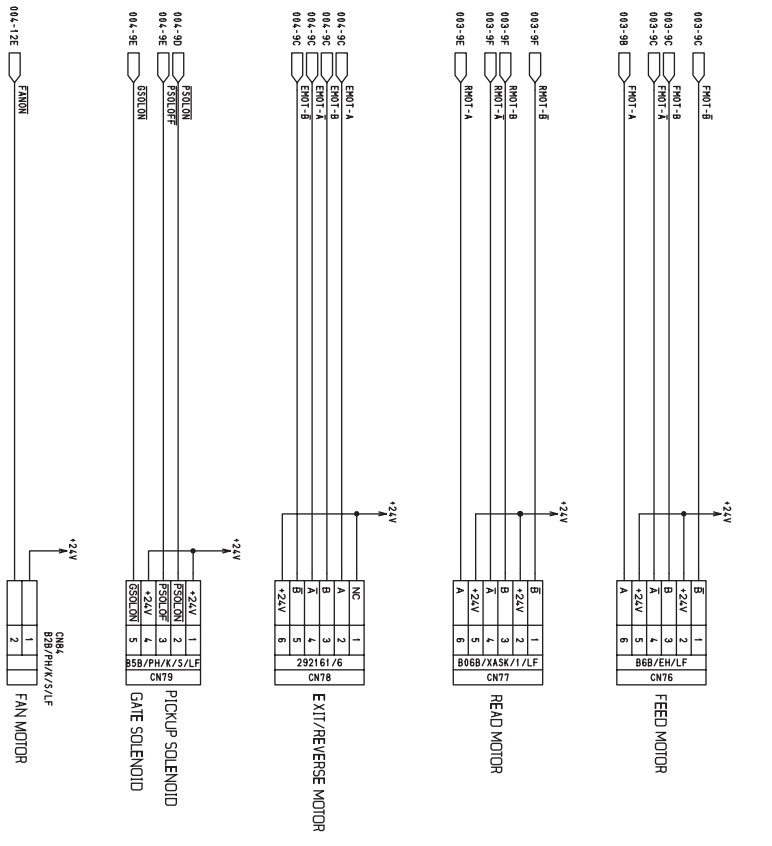

TOSHIBA

TOSHIBA TEC CORPORATION

2-17-2, HIGASHIGOTANDA, SHINAGAWA-KU, TOKYO, 141-8664, JAPAN